

ELECTRONIC CONTROL UNITS



Section / Description	page
REFERENCE TABLE	EC2
PWM DRIVERS	EC3
MACHINE MANAGEMENT SYSTEMS	EC19
GRAPHIC DISPLAY UNITS	EC33
ACCESSORIES	EC41

W 3 / 2016

WARNING: the specifications/application data shown in our catalogs and data sheets are intended only as a general guide for the product described (herein). Any specific application should not be undertaken without independent study, evaluation, and testing for suitability.



4484 Boeing Drive Rockford, IL 61109 • USA • Phone +1 (815) 397-6628 • Fax +1 (815) 397-2526
 mail: delta@delta-power.com • www.delta-power.com



Via Malavolti, 36 • 41122 Modena • ITALY • Phone +39 (059) 254895 • Fax +39 (059) 253512
 mail: tecnord@tecnord.com • www.tecnord.com

PWM DRIVERS

MODEL	DESCRIPTION	PAGE
EC-PWM-A1-MPC1-P	1 PWM output for single solenoid valve wire connection	EC4
EC-PWM-A1-MPC1-D	1 PWM output for single solenoid valve din plug for coil mounting	EC6
EC-PWM-A1-MPC1-E	1 PWM output for 1 single solenoid valve male DIN plug connection	EC8
EC-PWM-A2-MPC1-*	1 PWM output for 1 dual solenoid valve wire connection	EC10
EC-PWM-P4-MPC2-H	2 PWM outputs for 2 dual solenoid valves programmable	EC12
EC-PWM-08-MPC4-H	4 PWM outputs for 4 dual solenoid valves fixed settings	EC14
EC-PWM-P8-MPC4-H	4 PWM outputs for 4 dual solenoid valves programmable	EC16



EC-PWM-A1-MPC1-P PWM DRIVER**DESCRIPTION**

Microprocessor-based PWM electronic driver for remote control of a single proportional solenoid valve.

OPERATION

The EC-PWM-A1-MPC1-P proportional valve driver receives a command signal from a potentiometer, PLC or other control systems, and supplies a solenoid with a PWM (Pulse Width Modulated) current proportional to the input signal. An auxiliary power supply (+5 V) is provided as a reference for the command signal. Adjustments of "Imin/Imax", "Ramp time" and "Dither" can be carried out directly from a key-pad integrated on the front panel.

Mounting option: panel-mounting style with INPUT/OUTPUT multi-core sheathed cable.

FEATURES

- The current in the solenoid is independent from any change in the coil resistance or in the supply voltage.
- The inherent superimposed dither frequency helps to overcome friction and stiction effects in the controlled device.
- Power supply line is protected against reversed polarity and load dump.
- Input is protected against short circuits to GND and power supply.
- Output is protected against short circuits, over-current and over-temperature.
- The EC-PWM-A1-MPC1 is completely potted.
- Electro Magnetic Compatibility (EMC): EN 61000-6-2 (Immunity), EN 61000-6-3 (Emissions).

**SPECIFICATIONS**

Operating voltage:	8.5±30 VDC
Max current consumption:	100 mA (no load applied)
Operating temperature:	-25°C / +85°C
Input resistance 0÷5 V voltage input:	560 KOhms
0÷10 V voltage input:	1 MOhm
0÷20mA current input:	250 Ohms
Degree of protection:	IP 67
Analog input signals available:	0÷5 V 0÷10 V 0÷20 mA
Typical ctrl pot resistance:	2÷47 kΩ
Current output range (PWM):	100÷3000 mA
PWM dither frequency:	55±200 Hz (adjustable)
Ramp time:	0.05±5 s (adjustable)
Max. current from auxiliary +5 V:	15 mA

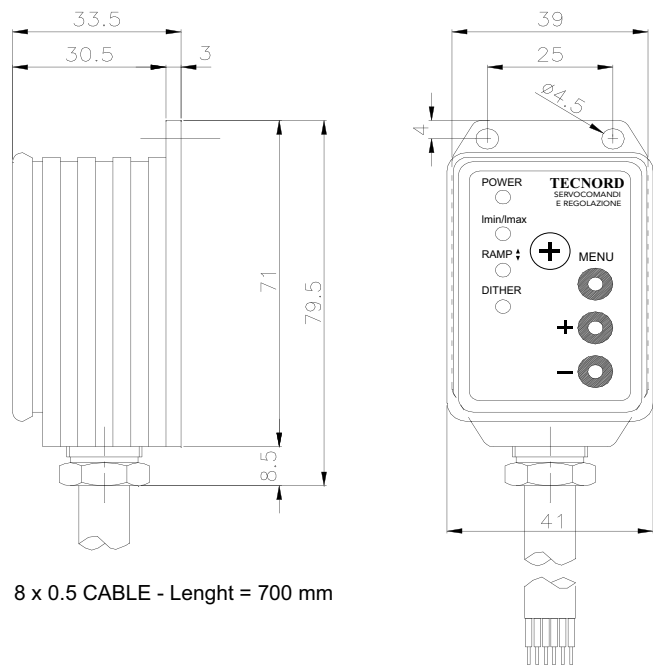
DIMENSIONS**APPLICATIONS**

Primary applications are the control of proportional pressure reducing valves and proportional flow regulators to attain smooth acceleration/ deceleration and fine-metering control of electro-hydraulic functions.

WARNING: the specifications/application data shown in our catalogs and data sheets are intended only as a general guide for the product described (herein). Any specific application should not be undertaken without independent study, evaluation, and testing for suitability.



4484 Boeing Drive Rockford, IL 61109 • USA • Phone +1 (815) 397-6628 • Fax +1 (815) 397-2526
mail: delta@delta-power.com • www.delta-power.com

TECNORD

Via Malavolti, 36 • 41122 Modena • ITALY • Phone +39 (059) 254895 • Fax +39 (059) 253512
mail: tecnord@tecnord.com • www.tecnord.com

EC-PWM-A1-MPC1-P PWM DRIVER

CIRCUIT BOARD PINOUT - WIRING DIAGRAM

Wiring Colours

- Blue** +Battery
- Brown** -Battery (GND)
- Red** Command signal supply (+5 V)
- Yellow** Command signal in
- Gray** Command signal GND
- White** Proportional coil output
- Green** Proportional coil current feedback line
- Pink** Spare / Not used

Note

A 5A fuse must be inserted on the BLUE wire connecting the PWM driver to the power source.

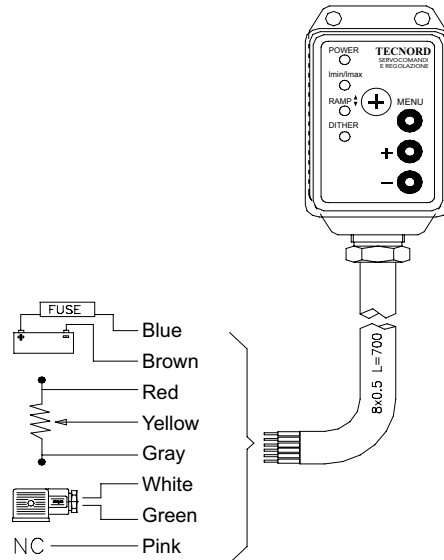

ADJUSTMENTS

The following adjustments can be made directly from the front key-pad by selecting the 3-pushpins in appropriate combinations:

- **Imin (minimum output current)**
- **Imax (maximum output current)**
- **Ramp-up time**
- **Ramp-down time**
- **Dither frequency**

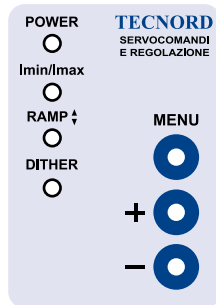

APPLICATION EXAMPLE

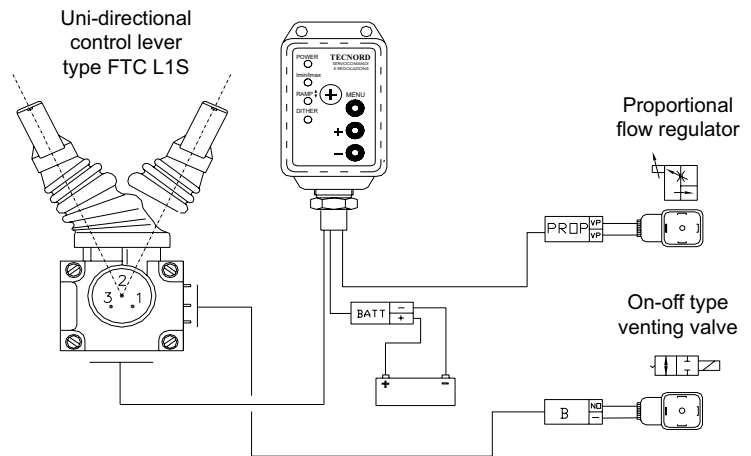

Remote operation of a proportional flow control valve from single axis/unidirectional control lever incorporating a rotary potentiometer and a center/power-off switch for the energization of an auxiliary solenoid-operated dump valve.

ORDERING INFORMATION

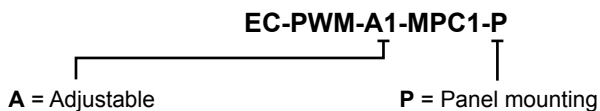

Part numbers	Version
23.0409.045	0-5 V
23.0409.087	0-10 V
23.0409.136	0-20 mA

W 3 / 2016

WARNING: the specifications/application data shown in our catalogs and data sheets are intended only as a general guide for the product described (herein). Any specific application should not be undertaken without independent study, evaluation, and testing for suitability.



4484 Boeing Drive Rockford, IL 61109 • USA • Phone +1 (815) 397-6628 • Fax +1 (815) 397-2526
 mail: delta@delta-power.com • www.delta-power.com



Via Malavolti, 36 • 41122 Modena • ITALY • Phone +39 (059) 254895 • Fax +39 (059) 253512
 mail: tecnord@tecnord.com • www.tecnord.com

EC-PWM-A1-MPC1-D PWM DRIVER**DESCRIPTION**

Microprocessor-based PWM electronic driver for remote control of a single proportional solenoid valve.

OPERATION

The EC-PWM-A1-MPC1-D proportional valve driver receives a command signal from a potentiometer, PLC or other control systems, and supplies a solenoid with a PWM (Pulse Width Modulated) current proportional to the input signal. An auxiliary power supply (+5 V) is provided as a reference for the command signal. Adjustments of "Imin/Imax", "Ramp time" and "Dither" can be carried out directly from a key-pad integrated on the front panel.

Mounting option: female DIN 43650 socket on valve's side and sheathed exit cable to connect to power source and remote control devices.

FEATURES

- The current in the solenoid is independent from any change in the coil resistance or in the supply voltage.
- The inherent superimposed dither frequency helps to overcome friction and stiction effects in the controlled device.
- Power supply line is protected against reversed polarity and load dump.
- Input is protected against short circuits to GND and power supply.
- Output is protected against short circuits, over-current and over-temperature.
- The EC-PWM-A1-MPC1 is completely potted.
- Electro Magnetic Compatibility (EMC): EN 61000-6-2 (Immunity), EN 61000-6-3 (Emissions).

**SPECIFICATIONS**

Operating voltage:	8.5±30 VDC
Max current consumption:	100 mA (no load applied)
Operating temperature:	-25°C / +85°C
Input resistance 0÷5 V voltage input:	560 KOhms
0÷10 V voltage input:	1 MOhm
0÷20mA current input:	250 Ohms
Degree of protection:	IP 67
Analog input signals available:	0÷5 V 0÷10 V 0÷20 mA
Typical ctrl pot resistance:	2÷47 kΩ
Current output range (PWM):	100÷3000 mA
PWM dither frequency:	55÷200 Hz (adjustable)
Ramp time:	0.05÷5 s (adjustable)
Max. current from auxiliary +5 V:	15 mA

APPLICATIONS

Primary applications are the control of proportional pressure reducing valves and proportional flow regulators to attain smooth acceleration/ deceleration and fine-metering control of electro-hydraulic functions.

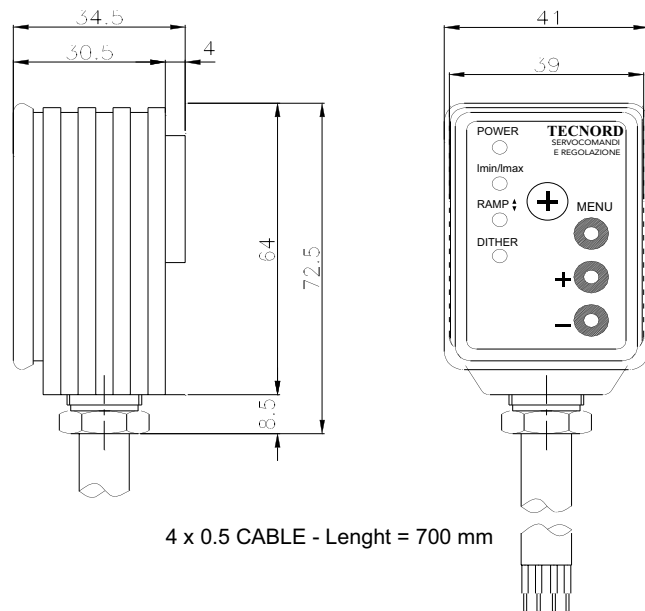
DIMENSIONS

WARNING: the specifications/application data shown in our catalogs and data sheets are intended only as a general guide for the product described (herein). Any specific application should not be undertaken without independent study, evaluation, and testing for suitability.



4484 Boeing Drive Rockford, IL 61109 • USA • Phone +1 (815) 397-6628 • Fax +1 (815) 397-2526
mail: delta@delta-power.com • www.delta-power.com

TECNORD

Via Malavolti, 36 • 41122 Modena • ITALY • Phone +39 (059) 254895 • Fax +39 (059) 253512
mail: tecnord@tecnord.com • www.tecnord.com

EC-PWM-A1-MPC1-D PWM DRIVER

CIRCUIT BOARD PINOUT - WIRING DIAGRAM

Power supply wiring colours

- Blue** (+) Positive from power source
- Yellow/Green** (-) Negative from (GND)

Remote potentiometer wiring colours

- Black** Command signal supply (+5 V)
- Brown** Command signal in

Proportional valve connector pins

- 1** Proportional coil output
- 2** Proportional coil current feedback line

Note

A 5A fuse must be inserted on the BLUE wire connecting the PWM driver to the power source.

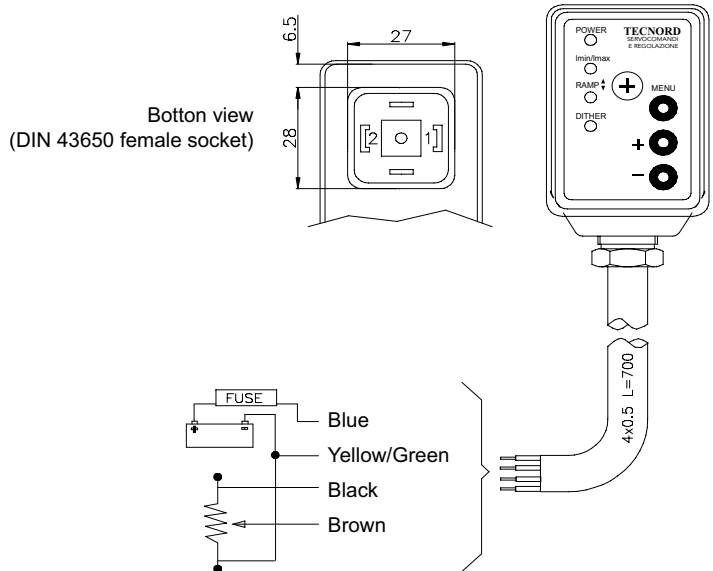

ADJUSTMENTS

The following adjustments can be made directly from the front key-pad by selecting the 3-pushpins in appropriate combinations:

- **Imin (minimum output current)**
- **Imax (maximum output current)**
- **Ramp-up time**
- **Ramp-down time**
- **Dither frequency**

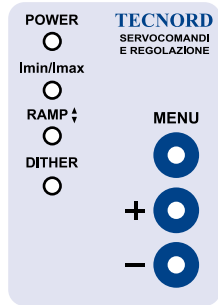

APPLICATION EXAMPLE

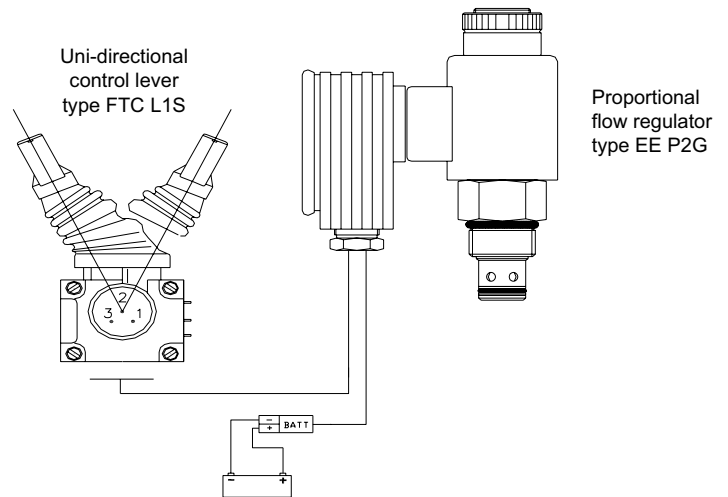

Remote operation of a proportional flow control valve from single axis/unidirectional control lever incorporating a rotary potentiometer.

ORDERING INFORMATION

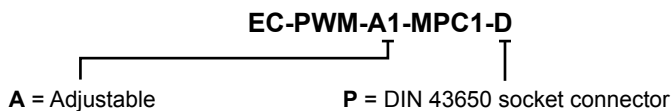

Part numbers	Version
23.0409.046	0-5 V
23.0409.065	0-10 V
23.0409.077	0-20 mA

W 3 / 2016

WARNING: the specifications/application data shown in our catalogs and data sheets are intended only as a general guide for the product described (herein). Any specific application should not be undertaken without independent study, evaluation, and testing for suitability.



4484 Boeing Drive Rockford, IL 61109 • USA • Phone +1 (815) 397-6628 • Fax +1 (815) 397-2526
 mail: delta@delta-power.com • www.delta-power.com



Via Malavolti, 36 • 41122 Modena • ITALY • Phone +39 (059) 254895 • Fax +39 (059) 253512
 mail: tecnord@tecnord.com • www.tecnord.com

EC-PWM-A1-MPC1-E PWM DRIVER**DESCRIPTION**

Microprocessor-based PWM electronic driver for remote control of a single proportional solenoid valve.

OPERATION

The EC-PWM-A1-MPC1-E proportional valve driver receives a command signal from a potentiometer, PLC or other control systems, and supplies a solenoid with a PWM (Pulse Width Modulated) current proportional to the input signal. An auxiliary power supply (+5 V) is provided as a reference for the command signal. Adjustments of "Imin/Imax", "Ramp time" and "Dither" can be carried out directly from a key-pad integrated on the front panel.

Mounting option: female DIN 43650 socket on valve's side and male DIN 43650 plug to connect to power source and remote control devices.

FEATURES

- The current in the solenoid is independent from any change in the coil resistance or in the supply voltage.
- The inherent superimposed dither frequency helps to overcome friction and stiction effects in the controlled device.
- Power supply line is protected against reversed polarity and load dump.
- Input is protected against short circuits to GND and power supply.
- Output is protected against short circuits, over-current and over-temperature.
- The EC-PWM-A1-MPC1 is completely potted.
- Electro Magnetic Compatibility (EMC): EN 61000-6-2 (Immunity), EN 61000-6-3 (Emissions).

**SPECIFICATIONS**

Operating voltage:	8.5±30 VDC
Max current consumption:	100 mA (no load applied)
Operating temperature:	-25°C / +85°C
Input resistance 0÷5 V voltage input:	560 KOhms
0÷10 V voltage input:	1 MOhm
0÷20mA current input:	250 Ohms
Degree of protection:	IP 67
Analog input signals available:	0÷5 V 0÷10 V 0÷20 mA
Typical ctrl pot resistance:	2÷47 kΩ
Current output range (PWM):	100÷3000 mA
PWM dither frequency:	55±200 Hz (adjustable)
Ramp time:	0.05±5 s (adjustable)
Max. current from auxiliary +5 V:	15 mA

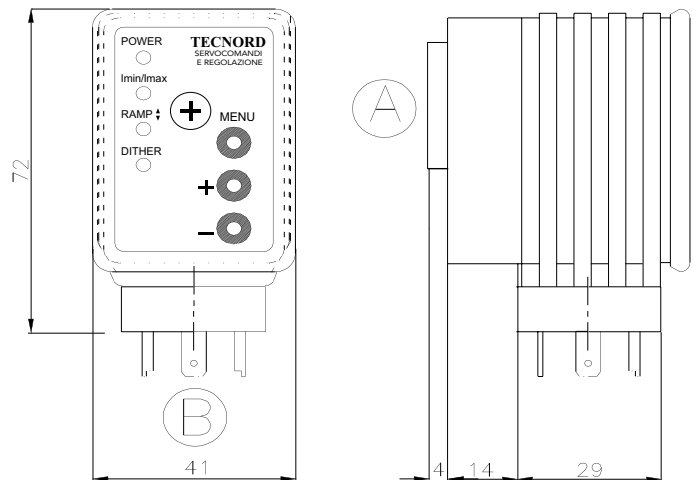
DIMENSIONS

A socket connector type DIN 43650 (to proportional valve)

B plug connector type DIN 43650
(from voltage supply and remote potentiometer)

APPLICATIONS

Primary applications are the control of proportional pressure reducing valves and proportional flow regulators to attain smooth acceleration/ deceleration and fine-metering control of electro-hydraulic functions.

WARNING: the specifications/application data shown in our catalogs and data sheets are intended only as a general guide for the product described (herein). Any specific application should not be undertaken without independent study, evaluation, and testing for suitability.



4484 Boeing Drive Rockford, IL 61109 • USA • Phone +1 (815) 397-6628 • Fax +1 (815) 397-2526
mail: delta@delta-power.com • www.delta-power.com

TECNORD

Via Malavolti, 36 • 41122 Modena • ITALY • Phone +39 (059) 254895 • Fax +39 (059) 253512
mail: tecnord@tecnord.com • www.tecnord.com

EC-PWM-A1-MPC1-E PWM DRIVER

CIRCUIT BOARD PINOUT - WIRING DIAGRAM

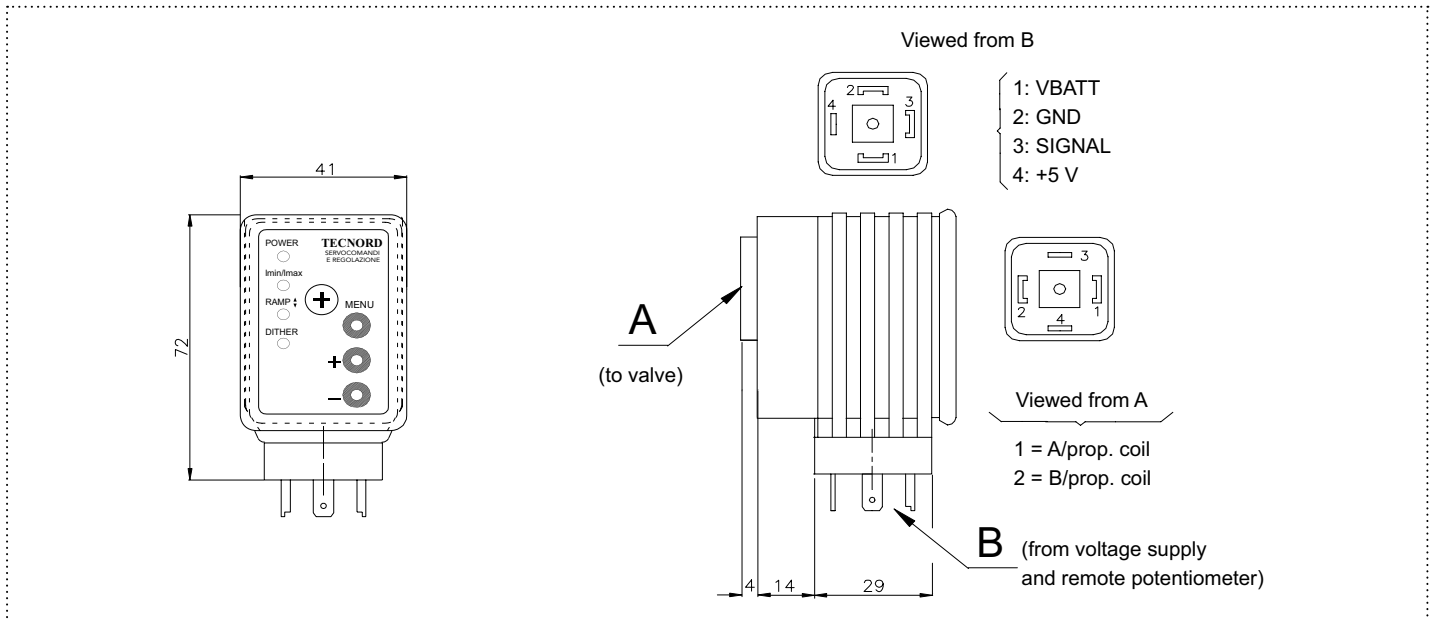

ADJUSTMENTS

The following adjustments can be made directly from the front key-pad by selecting the 3-pushpins in appropriate combinations:

- **Imin (minimum output current)**
- **Imax (maximum output current)**
- **Ramp-up time**
- **Ramp-down time**
- **Dither frequency**

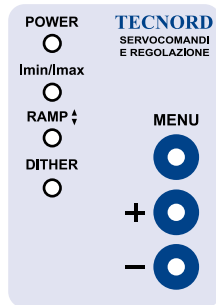

APPLICATION EXAMPLE

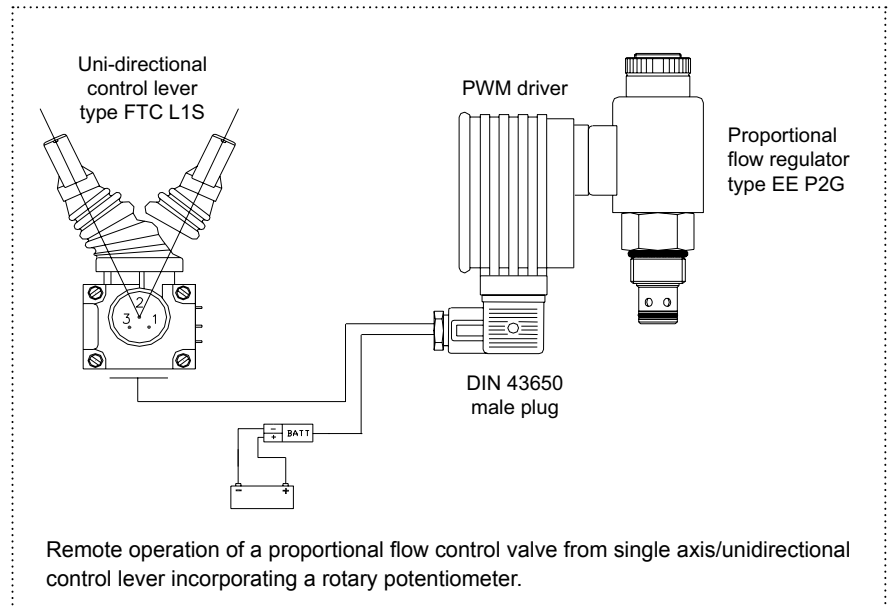

ORDERING INFORMATION

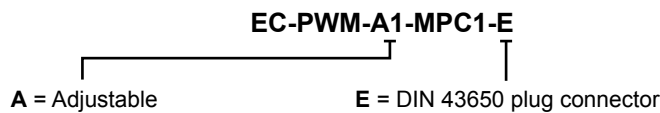

Part numbers	Version
23.0409.089	0-5 V
23.0409.047	0-10 V
23.0409.137	0-20 mA

W 3 / 2016

WARNING: the specifications/application data shown in our catalogs and data sheets are intended only as a general guide for the product described (herein). Any specific application should not be undertaken without independent study, evaluation, and testing for suitability.



4484 Boeing Drive Rockford, IL 61109 • USA • Phone +1 (815) 397-6628 • Fax +1 (815) 397-2526
 mail: delta@delta-power.com • www.delta-power.com



Via Malavolti, 36 • 41122 Modena • ITALY • Phone +39 (059) 254895 • Fax +39 (059) 253512
 mail: tecnord@tecnord.com • www.tecnord.com

EC-PWM-A2-MPC1-* PWM DRIVER**DESCRIPTION**

Microprocessor-based PWM electronic driver for remote control of a dual-coil proportional solenoid valve.

OPERATION

The EC-PWM-A2-MPC1 proportional valve driver supplies a double solenoid with a PWM (Pulse Width Modulated) current proportional to the input signal from a potentiometer, PLC or other control systems.

Proportional valve A is controlled with an input command signal varying from 2.5 to 4.5 V. Proportional valve B is controlled with an input command signal varying from 2.5 to 0.5 V. An auxiliary on-off type solenoid can be energised anytime the input signal goes out of the 2.25-2.75 V range.

FEATURES

- The current in the solenoid is independent from any change in the coil resistance or in the supply voltage.
- The inherent superimposed dither frequency helps to overcome friction and stiction effects in the controlled device.
- Supply line is protected against reversed polarity.
- Input is protected against short circuits to GND and supply.
- Outputs are protected against short circuits, reversed polarity, over-current and over-temperature.
- The EC-PWM-A2 circuit is potted inside a plastic enclosure suitable for panel mounting by means of 2 set screws.
- Electro Magnetic Compatibility (EMC): EN 61000-6-2 (Immunity), EN 61000-6-3 (Emissions).

**SPECIFICATIONS**

Operating voltage:	8÷32 VDC
Max current consumption:	100 mA (no load applied)
Operating temperature:	-25°C / +85°C
Degree of protection:	IP 68
Input impedance:	40 kΩ
Analog input signals:	0.5 - 2.5 - 4.5 VDC
Typical ctrl pot resistance:	2÷10 kΩ
Current output range (PWM):	100÷1500 mA
Current on-off output:	max 1800 mA
PWM dither frequency:	100 Hz
Resolution:	10 bits
DT04-8P Deutsch connector (male contacts)	

APPLICATIONS

- 12 VDC and 24 VDC systems.
- Remote control of proportional valves.
- Field-adjustable applications.
- Control of a proportional bidirectional valve with a venting valve.

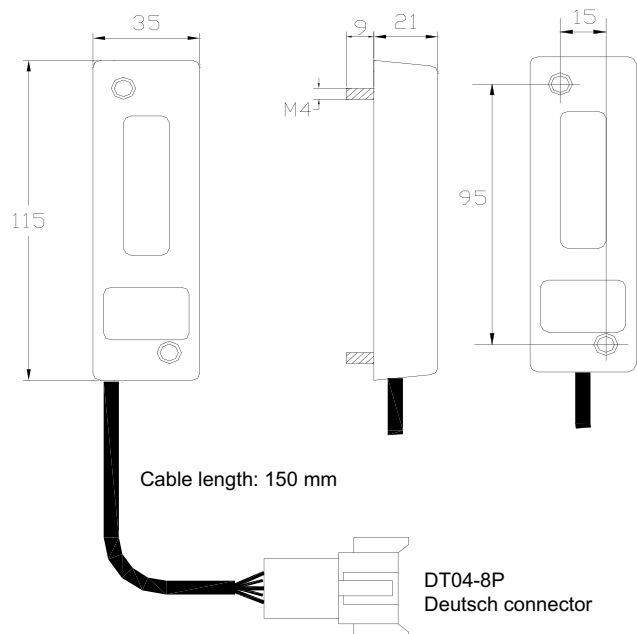
DIMENSIONS

WARNING: the specifications/application data shown in our catalogs and data sheets are intended only as a general guide for the product described (herein). Any specific application should not be undertaken without independent study, evaluation, and testing for suitability.



4484 Boeing Drive Rockford, IL 61109 • USA • Phone +1 (815) 397-6628 • Fax +1 (815) 397-2526
mail: delta@delta-power.com • www.delta-power.com

TECNORD

Via Malavolti, 36 • 41122 Modena • ITALY • Phone +39 (059) 254895 • Fax +39 (059) 253512
mail: tecnord@tecnord.com • www.tecnord.com

EC-PWM-A2-MPC1-* PWM DRIVER

H VERSION - PINOUT

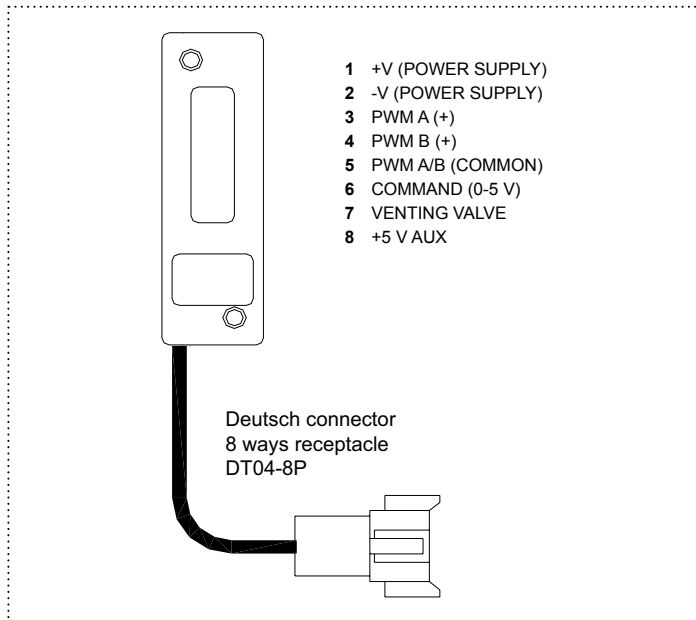

C VERSION - WIRING DIAGRAM

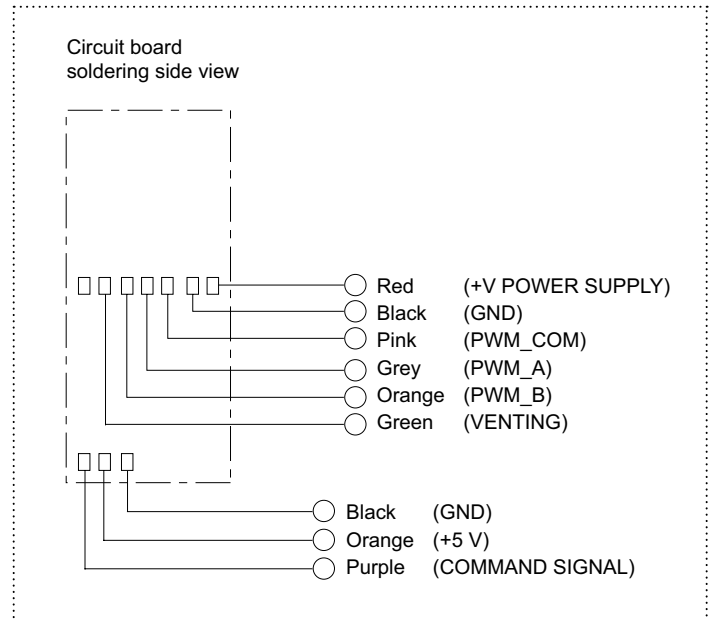

ADJUSTMENTS

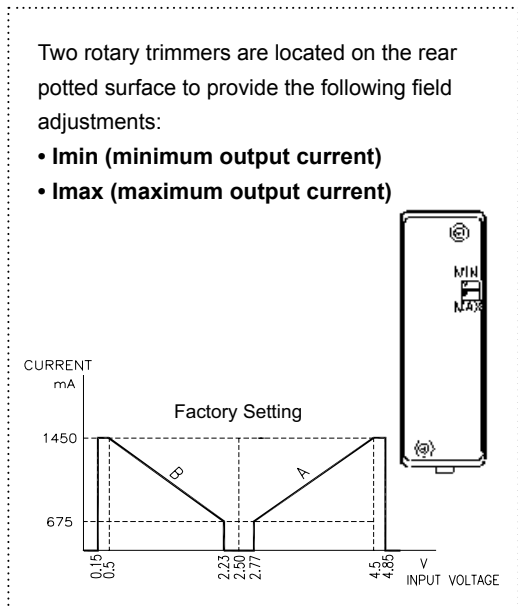

APPLICATION EXAMPLE

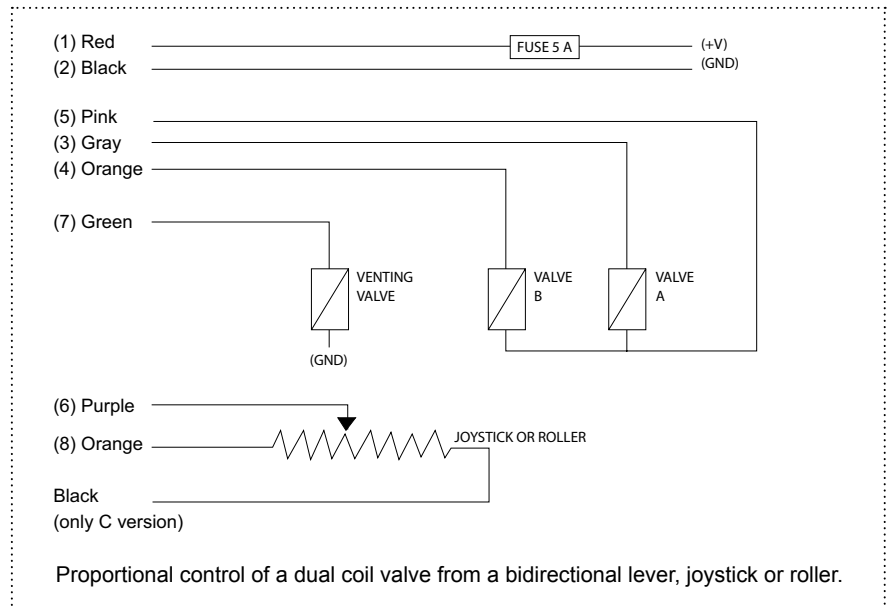

ORDERING INFORMATION

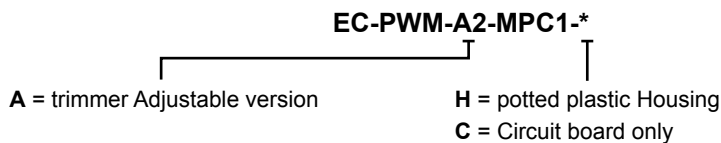

Part numbers	Version
23.0409.138	H
23.0409.109	C

W 3 / 2016

WARNING: the specifications/application data shown in our catalogs and data sheets are intended only as a general guide for the product described (herein). Any specific application should not be undertaken without independent study, evaluation, and testing for suitability.



4484 Boeing Drive Rockford, IL 61109 • USA • Phone +1 (815) 397-6628 • Fax +1 (815) 397-2526
mail: delta@delta-power.com • www.delta-power.com



Via Malavolti, 36 • 41122 Modena • ITALY • Phone +39 (059) 254895 • Fax +39 (059) 253512
mail: tecnord@tecnord.com • www.tecnord.com

EC-PWM-P4-MPC2-H PWM DRIVER**DESCRIPTION**

Microprocessor-based PWM driver for remote control of 2 dual-coil proportional solenoid valves.

OPERATION

The EC-PWM-P4-MPC2-H proportional valve driver supplies up to two dual-coil proportional valves with PWM (Pulse Width Modulated) current proportional to input signals coming from potentiometers, PLC or other control systems. The control characteristics (I_{min}/I_{max} , ramps, dither) are configurable via PC connected with a RS232 serial line to a configuration kit and PC interface of Tecnord supply.

FEATURES

- The current in the solenoid is independent from any change in the coil resistance or in the supply voltage.
- The inherent superimposed dither frequency helps to overcome friction and stiction effects in the controlled device.
- Supply line is protected against reversed polarity and load dump.
- Inputs are protected against short circuits to GND and supply.
- Outputs are protected against short circuits, reversed polarity, over-current and over-temperature.
- The EC-PWM-P4-MPC2-H is completely potted.
- Electro Magnetic Compatibility (EMC): EN 61000-6-2 (Immunity), EN 61000-6-3 (Emissions).

**SPECIFICATIONS**

Operating voltage:	9÷30 VDC
Max current consumption:	100 mA (no load applied)
Operating temperature:	-25°C / +85°C
Degree of protection:	IP 67
Input impedance:	100 kΩ
Analog inputs:	4 x 0-5 V
Typical ctrl pot resistance:	1÷10 kΩ
Digital inputs:	analog inputs can be used as digital
Resolution:	10 bit
PWM outputs channels:	2 x dual-coil proportional valves
Current output range (PWM):	100÷1500 mA (3 A version available)
PWM dither frequency:	75÷250 Hz (adjustable)
On-off digital output:	1 (1500 mA)

APPLICATIONS

- Specifically designed for applications requiring accurate adjustments and calibrations.
- 12 VDC and 24 VDC systems.
- Remote control of non-feedback proportional valves.
- Control of a proportional bidirectional valve with a venting valve.

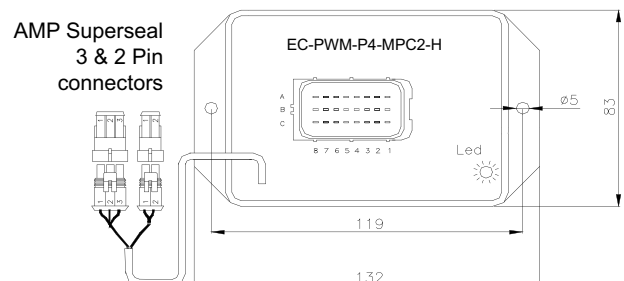
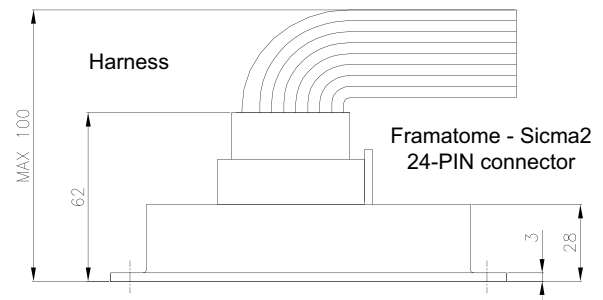
DIMENSIONS

WARNING: the specifications/application data shown in our catalogs and data sheets are intended only as a general guide for the product described (herein). Any specific application should not be undertaken without independent study, evaluation, and testing for suitability.



4484 Boeing Drive Rockford, IL 61109 • USA • Phone +1 (815) 397-6628 • Fax +1 (815) 397-2526
mail: delta@delta-power.com • www.delta-power.com

TECNORD

Via Malavolti, 36 • 41122 Modena • ITALY • Phone +39 (059) 254895 • Fax +39 (059) 253512
mail: tecnord@tecnord.com • www.tecnord.com

EC-PWM-08-MPC4-H PWM DRIVER**DESCRIPTION**

Microprocessor-based PWM driver for remote control of 4 dual-coil proportional solenoid valves.

OPERATION

The EC-PWM-08-MPC4 proportional valve driver supplies up to four dual-coil proportional solenoid valves with PWM (Pulse Width Modulated) current proportional to the input signals coming from potentiometers, PLC or other control systems. PWM currents are factory pre-set and cannot be adjusted.

FEATURES

- The current in the solenoid is independent from any change in the coil resistance or in the supply voltage.
- The inherent superimposed dither frequency helps to overcome friction and stiction effects in the controlled device.
- Supply line is protected against reversed polarity and load dump.
- Inputs are protected against short circuits to GND and supply.
- Outputs are protected against short circuits, reversed polarity, over-current and over-temperature.
- The EC-PWM-08-MPC4-H is completely potted.
- Electro Magnetic Compatibility (EMC): EN 61000-6-2 (Immunity), EN 61000-6-3 (Emissions).

**SPECIFICATIONS**

Operating voltage:	9÷30 VDC
Max current consumption:	100 mA (no load applied)
Operating temperature:	-40°C / +100°C
Degree of protection:	IP 67
Input impedance:	100 kΩ
Analog inputs:	6 x 0-5 V
Typical ctrl pot resistance:	1÷10 kΩ
Digital inputs:	2 x PNP (Active High)
Resolution:	10 bit
PWM outputs channels:	4 x dual-coil proportional valves
Current output range (PWM):	100÷1500 mA
PWM dither frequency:	75÷250 Hz (factory pre-set, standard 100 Hz)

APPLICATIONS

- Specifically designed for applications with factory-set working parameters and requiring no field-adjustments.
- 12 VDC and 24 VDC systems.
- Remote control of proportional valves.
- Control of a 4 functions proportional bidirectional system.

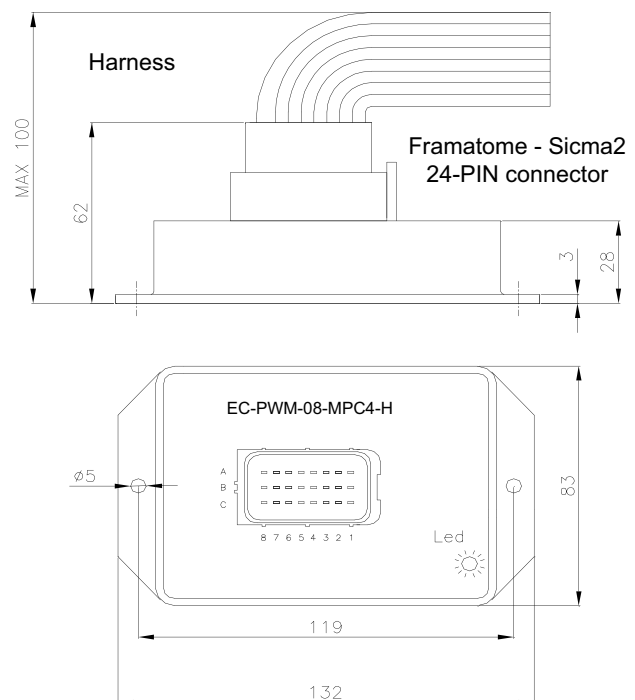
DIMENSIONS

WARNING: the specifications/application data shown in our catalogs and data sheets are intended only as a general guide for the product described (herein). Any specific application should not be undertaken without independent study, evaluation, and testing for suitability.



4484 Boeing Drive Rockford, IL 61109 • USA • Phone +1 (815) 397-6628 • Fax +1 (815) 397-2526
mail: delta@delta-power.com • www.delta-power.com

TECNORD

Via Malavolti, 36 • 41122 Modena • ITALY • Phone +39 (059) 254895 • Fax +39 (059) 253512
mail: tecnord@tecnord.com • www.tecnord.com

EC-PWM-P8-MPC4-H PWM DRIVER**DESCRIPTION**

Microprocessor-based PWM driver for remote control of 4 dual-coil proportional solenoid valves.

OPERATION

The EC-PWM-P8-MPC4 proportional valve driver supplies up to four dual-coil proportional solenoid valves with PWM (Pulse Width Modulated) current proportional to the input signals coming from potentiometers, PLC or other control systems. The control characteristics (I_{min}/I_{max} , ramps, dither) are configurable via PC connected with a RS232 serial line to a configuration kit and PC interface of Tecnom supply.

FEATURES

- The current in the solenoid is independent from any change in the coil resistance or in the supply voltage.
- The inherent superimposed dither frequency helps to overcome friction and stiction effects in the controlled device.
- Supply line is protected against reversed polarity and load dump.
- Inputs are protected against short circuits to GND and supply.
- Outputs are protected against short circuits, reversed polarity, over-current and over-temperature.
- The EC-PWM-P8-MPC4-H is completely potted.
- Electro Magnetic Compatibility (EMC): EN 61000-6-2 (Immunity), EN 61000-6-3 (Emissions).

**SPECIFICATIONS**

Operating voltage:	9÷30 VDC
Max current consumption:	100 mA (no load applied)
Operating temperature:	-25°C / +85°C
Degree of protection:	IP 67
Input impedance:	100 kΩ
Analog inputs:	8 x 0-5 V
Typical ctrl pot resistance:	1÷10 kΩ
Digital inputs:	analog inputs can be used as digital
Resolution:	10 bit
PWM outputs channels:	4 x dual-coil proportional valves
Current output range (PWM):	100÷1500 mA (3 A version available)
PWM dither frequency:	75÷250 Hz (adjustable)

APPLICATIONS

- Specifically designed for applications requiring accurate adjustments and calibrations.
- 12 VDC and 24 VDC systems.
- Remote control of non-feedback proportional valves.
- Control of up to 4 proportional bidirectional valves.

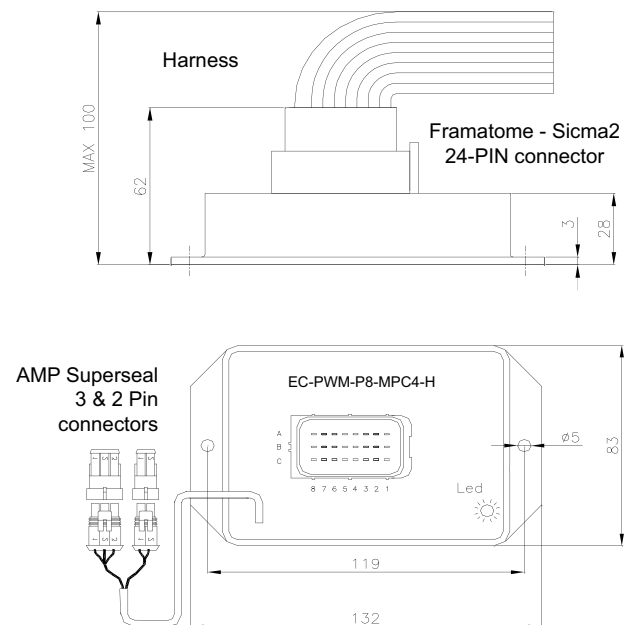
DIMENSIONS

WARNING: the specifications/application data shown in our catalogs and data sheets are intended only as a general guide for the product described (herein). Any specific application should not be undertaken without independent study, evaluation, and testing for suitability.



4484 Boeing Drive Rockford, IL 61109 • USA • Phone +1 (815) 397-6628 • Fax +1 (815) 397-2526
mail: delta@delta-power.com • www.delta-power.com

TECNORD

Via Malavolti, 36 • 41122 Modena • ITALY • Phone +39 (059) 254895 • Fax +39 (059) 253512
mail: tecnord@tecnord.com • www.tecnord.com

WARNING: the specifications/application data shown in our catalogs and data sheets are intended only as a general guide for the product described (herein). Any specific application should not be undertaken without independent study, evaluation, and testing for suitability.



4484 Boeing Drive Rockford, IL 61109 • USA • Phone +1 (815) 397-6628 • Fax +1 (815) 397-2526
mail: delta@delta-power.com • www.delta-power.com



Via Malavolti, 36 • 41122 Modena • ITALY • Phone +39 (059) 254895 • Fax +39 (059) 253512
mail: tecnord@tecnord.com • www.tecnord.com

MACHINE MANAGEMENT SYSTEMS

MODEL	DESCRIPTION	PAGE
EC-MMS-1012-H	10 inputs, 12 outputs meter-in systems controller	EC20
EC-MMS-2218-H	22 inputs, 18 outputs RS232 / RS 485 interface	EC22
EC-MMS-1521-H	15 inputs, 21 outputs CANbus interface	EC24
EC-MMS-4820-H	48 inputs, 20 outputs RS 485 / CANbus interface	EC26
EC-MMS-0713-H	7 inputs, 13 outputs Deutsch connection / RS 485 interface	EC28
EC-MMS-6252-H	62 inputs, 52 output RS485 / CANbus interface	EC30



EC-MMS-1012-H MACHINE MANAGEMENT SYSTEM

DESCRIPTION

Digital MMS (Machine Management System) with built-in advanced safety and fault detection features for integrated control of mobile equipment functions.

OPERATION

10 inputs and 12 outputs are managed by this small-size unit. PWM current outputs are field-adjustable and their setting is stored in a EEPROM memory. Parameters can be loaded via software from a standard PC connected with a RS232 serial line. It can be used as a stand-alone controller for both meter-in systems (up to 5 functions) and bidirectional proportional systems (up to 4 functions). Additional output for a safety venting valve is available.

FEATURES

- Supply line is protected against reversed polarity and overvoltage.
- Inputs are protected against short circuits to GND and power supply.
- Outputs are protected against short circuits, reversed polarity, over-current and over-temperature.
- 3-wires RS232 serial interface.
- Auxiliary +5 V supply for control devices (e.g. potentiometers).
- Performance level c capability according to ISO 13849, due to high reliability of components and embedded diagnostics.
- Electro Magnetic Compatibility (EMC): EN 61000-6-2 (Immunity), EN 61000-6-3 (Emissions).



SPECIFICATIONS

Operating voltage:	9+30 VDC
Max current consumption:	100 mA (no load applied)
Operating temperature:	-25°C / +85°C
Degree of protection:	IP 67
Input impedance:	100 kΩ
Analog inputs (10 bits):	8 (0-5 V)
Typical ctrl pot resistance:	1+10 kΩ
Digital inputs:	2
High side power outputs:	12 (3.5 A max)
Inputs for current feedback:	4
Current output range (PWM):	100+1500 mA
PWM dither frequency:	60+200 Hz

APPLICATIONS

- 12 VDC and 24 VDC systems.
- Remote control of non-feedback proportional and on-off valves.
- Specifically designed for applications requiring accurate adjustments and calibrations.
- Control of up to 4 proportional bidirectional valves plus a venting valve and additional 3 auxiliary outputs.
- Control of up to 5 functions in meter-in configuration (10 on-off valves plus 1 proportional valve and 1 venting valve).

DIMENSIONS

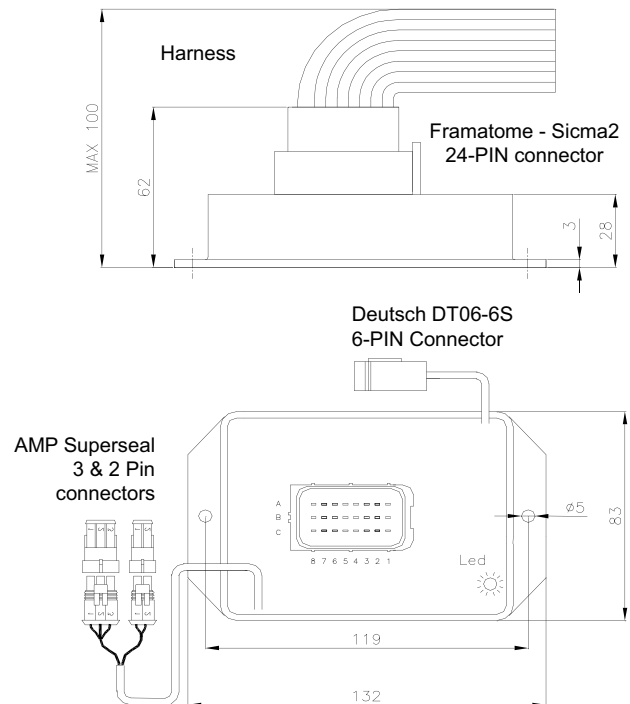

WARNING: the specifications/application data shown in our catalogs and data sheets are intended only as a general guide for the product described (herein). Any specific application should not be undertaken without independent study, evaluation, and testing for suitability.



4484 Boeing Drive Rockford, IL 61109 • USA • Phone +1 (815) 397-6628 • Fax +1 (815) 397-2526
 mail: delta@delta-power.com • www.delta-power.com



Via Malavolti, 36 • 41122 Modena • ITALY • Phone +39 (059) 254895 • Fax +39 (059) 253512
 mail: tecnord@tecnord.com • www.tecnord.com

EC-MMS-1012-H MACHINE MANAGEMENT SYSTEM

CIRCUIT BOARD PINOUT - WIRING DIAGRAM (reference: meter-in layout)

Connector type: framatome SICMA2

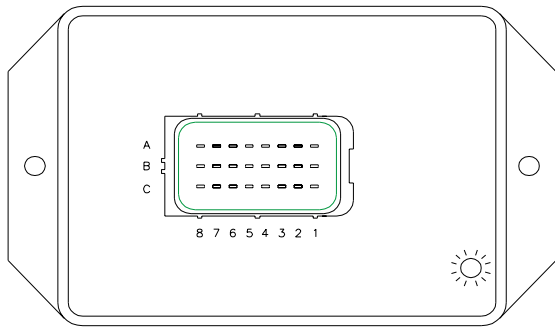

- A**
- 1 EV4A (HIGH SIDE)
 - 2 EV4B (HIGH SIDE)
 - 3 EV3A (HIGH SIDE)
 - 4 EV3B (HIGH SIDE)
 - 5 ANALOG IN 4
 - 6 ANALOG IN 3
 - 7 ANALOG IN 1
 - 8 PROP. CURRENT FEEDBACK

- B**
- 1 +V (POWER SUPPLY)
 - 2 EV9 (VENTING - HIGH SIDE)
 - 3 ANALOG IN - SPARE
 - 4 ANALOG IN 2
 - 5 ANALOG IN 5
 - 6 PROP. CURRENT FEEDBACK - SPARE
 - 7 PROP. CURRENT FEEDBACK - SPARE
 - 8 PROP. CURRENT FEEDBACK - SPARE

Connector type: AMP-Seal

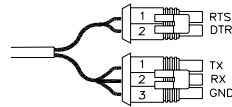

- For software download
- 1 RTS
 - 2 DTR
- For calibration and adjustments
- 1 TX
 - 2 RX
 - 3 GND

Connector type: Deutsch DT06-6S

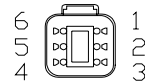

- 1 DIGITAL IN - SPARE
 - 2 DIGITAL IN - DEAD MAN
 - 3 NOT CONNECTED
 - 4 EV1A (HIGH SIDE)
 - 5 EV1B (HIGH SIDE)
 - 6 EV5B (HIGH SIDE)
- C**
- 1 -V (POWER SUPPLY - GND)
 - 2 5V EXT
 - 3 ANALOG IN - SPARE
 - 4 ANALOG IN - SPARE
 - 5 EVP (HIGH SIDE)
 - 6 EV5A (HIGH SIDE)
 - 7 EV2A (HIGH SIDE)
 - 8 EV2B (HIGH SIDE)

ADJUSTMENTS

Adjustments can be effected via RS232 serial line to modify the following work parameters:

- **I_{min}** (minimum output current)
- **I_{max}** (maximum output current)
- **Ramp-up time**
- **Ramp-down time**
- **Dither frequency**

Calibration tool ordering code: **20.1001.026/A**
RS232 cable adapter for PC connection including calibration software on CD (see page EC44-45).

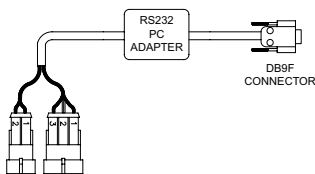

Note: USB/RS232 interface available on request.

APPLICATION EXAMPLE

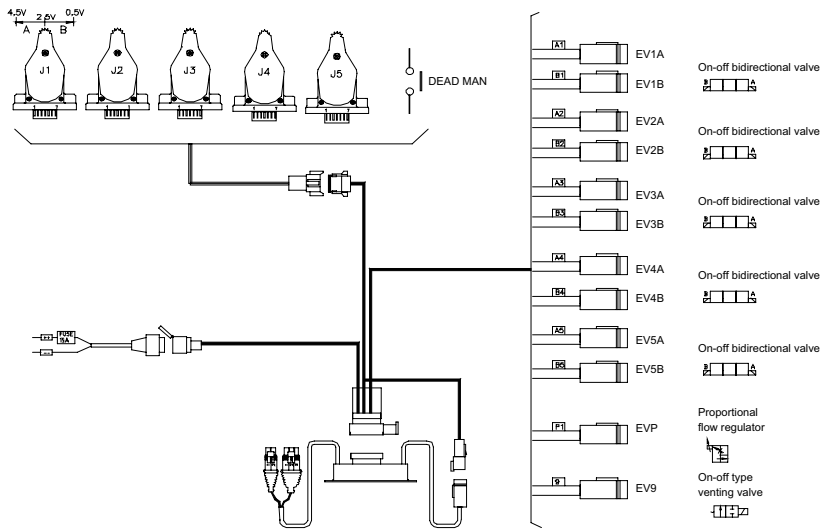

ORDERING INFORMATION

EC-MMS-1012-H

1012 = 10 inputs - 12 outputs

H = potted plastic
Housing for panel mounting

Part number (Std Version)

23.0409.177

W 3 / 2016

WARNING: the specifications/application data shown in our catalogs and data sheets are intended only as a general guide for the product described (herein). Any specific application should not be undertaken without independent study, evaluation, and testing for suitability.



4484 Boeing Drive Rockford, IL 61109 • USA • Phone +1 (815) 397-6628 • Fax +1 (815) 397-2526
mail: delta@delta-power.com • www.delta-power.com



Via Malavolti, 36 • 41122 Modena • ITALY • Phone +39 (059) 254895 • Fax +39 (059) 253512
mail: tecnord@tecnord.com • www.tecnord.com

EC-MMS-2218-H MACHINE MANAGEMENT SYSTEM**DESCRIPTION**

Digital MMS (Machine Management System) with built-in advanced safety and fault detection features for integrated control of Mobile Equipment functions. CANbus capability make it suitable for high-end network systems.

OPERATION

22 inputs and 18 outputs are managed by this small-size unit. Analog outputs are field-adjustable and their setting is stored in an EEPROM memory and can be loaded via software from vehicle's controller through CANbus or from a standard PC connected through an RS232 serial line. It can be used as a stand-alone controller or in conjunction with other MMS electronic units like Tecnord's Mod. MMS-4820.

FEATURES

- Power Supply line is protected against reversed polarity and overvoltage.
- Inputs are protected against short circuits to GND and supply.
- High resolution, 16-bits, analog inputs.
- Outputs are protected against short circuits, reversed polarity, over-current and over-temperature.
- CANbus serial interface.
- RS232 serial interface.
- Especially designed to drive up to 6 electro-hydraulic proportional actuators Tecnord type MLT-FD4/5.
- Auxiliary +5 V supply for control devices (e.g. potentiometers).
- Performance Level c capability according to ISO 13849, due to high reliability of components and embedded diagnostics.
- Electro Magnetic Compatibility (EMC): EN 61000-6-2 (Immunity), EN 61000-6-3 (Emissions).

**SPECIFICATIONS**

Operating voltage:	8÷32 VDC
Max current consumption:	0.5 A (no load applied)
Operating temperature:	-30 ÷ +85°C
Degree of protection:	IP 67
Analog inputs (10 bits):	8 (0-5 V)
Input impedance:	100 kΩ
Typical ctrl pot resistance:	1÷10 kΩ
Digital inputs:	14
High side power outputs:	12 (3.5 A max)
PWM current feedback:	1
Max current load on all outputs:	10 A
Analog outputs:	6 (0-5 V)

APPLICATIONS

- 12 VDC and 24 VDC systems.
- Closed loop systems with electro-hydraulic proportional actuators.
- General purpose applications requiring field-adjustments.
- MMS-2218 can be connected to a CANbus network (J1939 or CANopen).

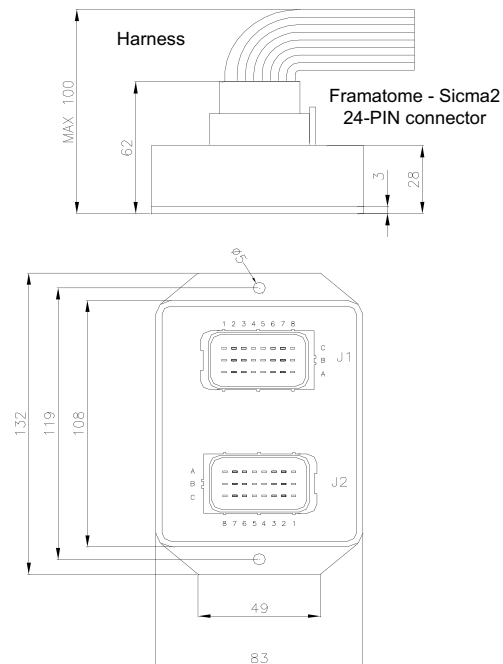
DIMENSIONS

WARNING: the specifications/application data shown in our catalogs and data sheets are intended only as a general guide for the product described (herein). Any specific application should not be undertaken without independent study, evaluation, and testing for suitability.



4484 Boeing Drive Rockford, IL 61109 • USA • Phone +1 (815) 397-6628 • Fax +1 (815) 397-2526
mail: delta@delta-power.com • www.delta-power.com

TECNORD

Via Malavolti, 36 • 41122 Modena • ITALY • Phone +39 (059) 254895 • Fax +39 (059) 253512
mail: tecnord@tecnord.com • www.tecnord.com

EC-MMS-2218-H MACHINE MANAGEMENT SYSTEM

CIRCUIT BOARD PINOUT - WIRING DIAGRAM

Connector type: framatome SICMA2

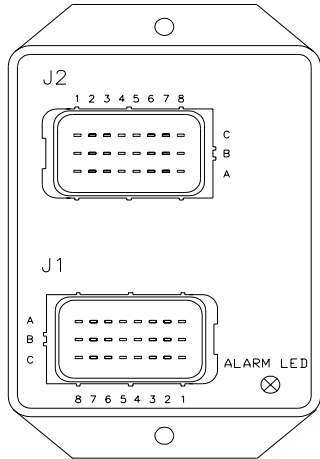

J1		
A	B	C
1 ANALOG IN 2	1 ANALOG IN 1	1 ANALOG IN 0
2 ANALOG IN 5	2 ANALOG IN 4	2 ANALOG IN 3
3 DIGITAL IN 0	3 ANALOG IN 7	3 ANALOG IN 6
4 DIGITAL IN 2	4 DIGITAL IN 1	4 5V EXT
5 DIGITAL IN 4	5 DIGITAL IN 3	5 RS232 GND
6 DIGITAL IN 7	6 DIGITAL IN 6	6 DIGITAL IN 5
7 DIGITAL IN 9	7 DIGITAL IN 8	7 DIGITAL IN 10
8 RS232 TX	8 RS232 RX	8 DIGITAL IN 11
J2		
A	B	C
1 OUT 0 (WITH FEEDBACK)	1 OUT 7	1 OUT 6
2 OUT 1	2 CAN L	2 OUT 9
3 OUT 2	3 ANALOG OUT 0	3 OUT 8
4 OUT 3	4 CAN H	4 OUT 11
5 OUT 4	5 ANALOG OUT 2	5 OUT 10
6 OUT 5	6 ANALOG OUT 1	6 DIGITAL IN 12
7 ANALOG OUT 4	7 ANALOG OUT 5	7 DIGITAL IN 13
8 -V (POWER SUPPLY - GND)	8 +V (POWER SUPPLY)	8 ANALOG OUT 3

ADJUSTMENTS

MMS controllers have a customized firmware to fulfill machine functions. A customized calibration tool is available to set main working parameters.



Ask for: PC calibration tool (see page EC44)

APPLICATION EXAMPLE

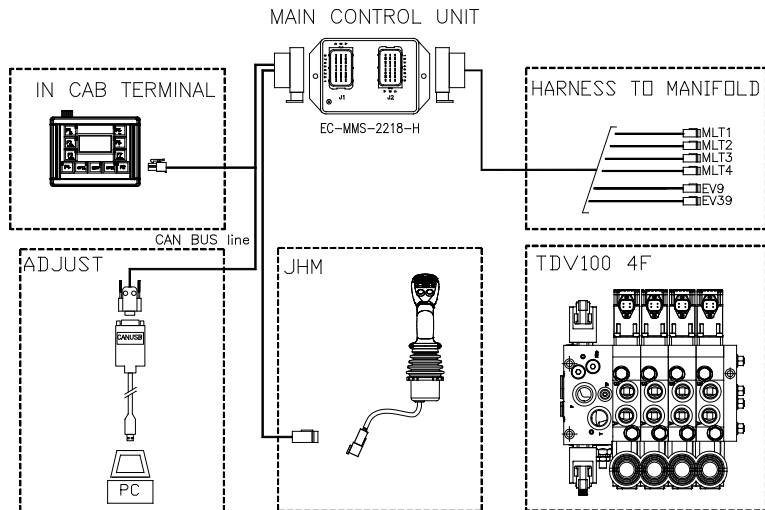

Electro-hydraulic multi-function system requiring individual calibration of each semi-function to meet specific working or safety-related conditions.

ORDERING INFORMATION

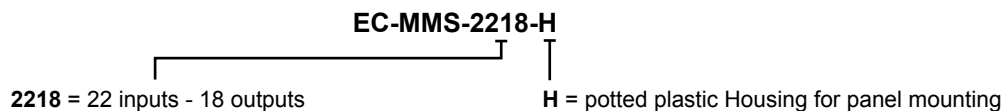

W 3 / 2016

WARNING: the specifications/application data shown in our catalogs and data sheets are intended only as a general guide for the product described (herein). Any specific application should not be undertaken without independent study, evaluation, and testing for suitability.



4484 Boeing Drive Rockford, IL 61109 • USA • Phone +1 (815) 397-6628 • Fax +1 (815) 397-2526
 mail: delta@delta-power.com • www.delta-power.com



Via Malavolti, 36 • 41122 Modena • ITALY • Phone +39 (059) 254895 • Fax +39 (059) 253512
 mail: tecnord@tecnord.com • www.tecnord.com

EC-MMS-1521-H MACHINE MANAGEMENT SYSTEM CONTROLLER**DESCRIPTION**

MMS (Machine Management System) controller in rugged aluminum enclosure dual microprocessor, CANbus, built-in safety and fault-detection features for integrated control of complex functions in mobile equipment applications.

OPERATION

It is normally used as the main control unit in a complete management system. Two microprocessors and advanced diagnostics for safety applications. The EC-MMS-1521 comes with an aluminium casing, a silicon rubber gasket and connectors, designed to ensure power dissipation, robustness and tightness required in severe environment conditions. Software download available.

FEATURES

- Robust aluminum enclosure.
- Power supply is protected against reversed polarity (external fuse required) and overvoltage.
- Inputs are protected against short circuits to GND and power supply.
- Outputs protected against short circuits, over-current and over-temperature.
- 2 CANbus connections.
- PWM drivers with current feedback.
- +5 V auxiliary power supply for external control devices.
- Performance level d capability according to ISO 13849, thanks to redundant microcontroller and embedded diagnostics.
- Electro Magnetic Compatibility (EMC): EN 61000-6-2 (Immunity), EN 61000-6-3 (Emissions).
- Reserved power supply pins for safety power outputs.
- Optional add-on inclinometer.
- Optional real time clock for data logging.

**SPECIFICATIONS**

Operating voltage:	8÷32 VDC
Max. current consumption:	< 400 mA (no load applied)
Operating temperature:	-40°C / +105°C
Degree of protection:	IP 69
Analog inputs (16 bits):	3 (0-5 V)
Analog inputs (10 bits):	8 (0-5 V)
Digital (frequency) inputs:	4
High side power outputs:	18 (6 if PWM outputs are used)
Low side power outputs (LS):	2
PWM outputs with current feedback (3A):	12
Analog voltage outputs (0-5 V):	1
Pins selectable as power OUT or digital IN:	6
Inputs with SW selectable pull-up:	4
CANbus lines:	2 (ISO 11898, CAN 2.0A/B)
Available bus speed:	up to 1 Mbit/s

APPLICATIONS

- Main ECU for aerial platforms, cranes, telehandlers, agriculture vehicles.
- 12 VDC and 24 VDC systems.
- Two or more MMS boards can be interconnected through the CANbus line.

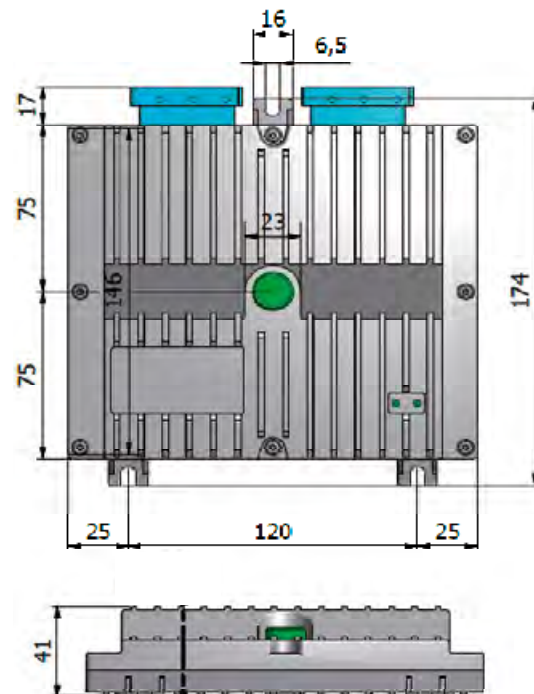
DIMENSIONS

WARNING: the specifications/application data shown in our catalogs and data sheets are intended only as a general guide for the product described (herein). Any specific application should not be undertaken without independent study, evaluation, and testing for suitability.



4484 Boeing Drive Rockford, IL 61109 • USA • Phone +1 (815) 397-6628 • Fax +1 (815) 397-2526
mail: delta@delta-power.com • www.delta-power.com

TECNORD

Via Malavolti, 36 • 41122 Modena • ITALY • Phone +39 (059) 254895 • Fax +39 (059) 253512
mail: tecnord@tecnord.com • www.tecnord.com

EC-MMS-1521-H MACHINE MANAGEMENT SYSTEM CONTROLLER

CIRCUIT BOARD PINOUT - WIRING DIAGRAM

Connector type: framatome SICMA2

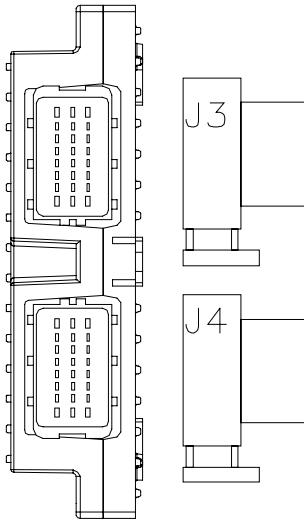

J3 (GREY)

- A**
- 1 VHS4
- 2 OUT_PWM7
- 3 OUT_PWM2
- 4 OUT_PWM3
- 5 DIG INT 1
- 6 DIG INT 0
- 7 OUT_PWM4
- 8 VHS3

- B**
- 1 LS1
- 2 OUT_PWM6
- 3 ANALOG IN 8
- 4 ANALOG IN 10
- 5 DIG INT 3
- 6 DIG INT 2
- 7 OUT_PWM5
- 8 VHS2

- C**
- 1 LS0
- 2 5V EXT
- 3 ANALOG IN 9
- 4 CAN L 1
- 5 CAN H 1
- 6 CAN L 2
- 7 CAN H 2
- 8 VHS1

J4 (BLACK)

- A**
- 1 OUT 4
- 2 OUT 5
- 3 OUT 0
- 4 OUT 1
- 5 OUT_PWM8
- 6 OUT_PWM9
- 7 OUT_PWM10
- 8 +V (POWER SUPPLY)

- B**
- 1 OUT 2
- 2 OUT 3
- 3 ANALOG IN 1
- 4 ANALOG IN 3
- 5 ANALOG IN 5
- 6 ANALOG IN 7
- 7 OUT_PWM11
- 8 -V (POWER SUPPLY - GND)

- C**
- 1 OUT_PWM0
- 2 OUT_PWM1
- 3 ANALOG IN 0
- 4 ANALOG IN 2
- 5 ANALOG IN 4
- 6 ANALOG IN 6
- 7 OUT AN 0
- 8 -V (POWER SUPPLY - GND)

ADJUSTMENTS

MMS controllers have a customized firmware to fulfill machine functions. A customized calibration tool is available to set main working parameters.



Ask for: PC calibration tool (see page EC44)

APPLICATION EXAMPLE

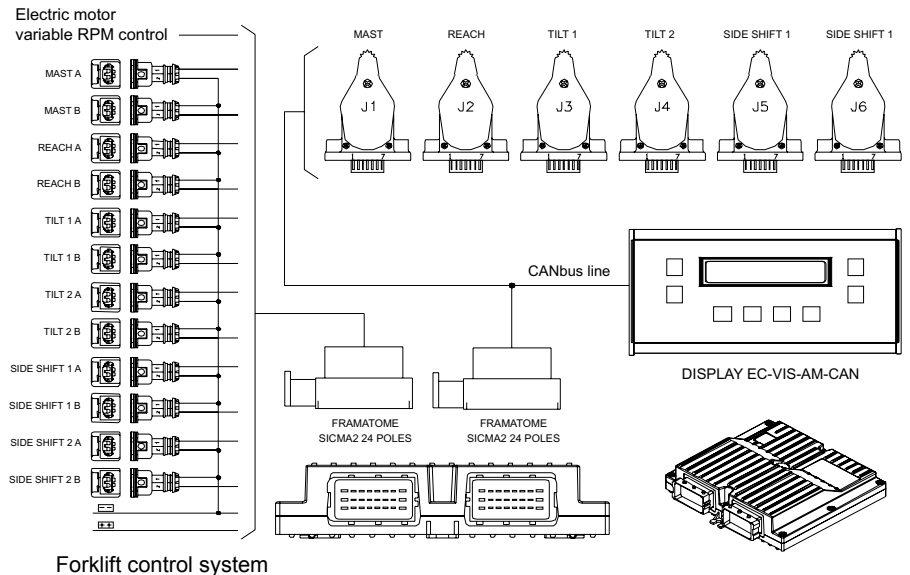

ORDERING INFORMATION



W 3 / 2016

WARNING: the specifications/application data shown in our catalogs and data sheets are intended only as a general guide for the product described (herein). Any specific application should not be undertaken without independent study, evaluation, and testing for suitability.



4484 Boeing Drive Rockford, IL 61109 • USA • Phone +1 (815) 397-6628 • Fax +1 (815) 397-2526
 mail: delta@delta-power.com • www.delta-power.com



Via Malavolti, 36 • 41122 Modena • ITALY • Phone +39 (059) 254895 • Fax +39 (059) 253512
 mail: tecnord@tecnord.com • www.tecnord.com

EC-MMS-4820-H MACHINE MANAGEMENT SYSTEM

DESCRIPTION

MMS (Machine Management System) coding card with CANbus and RS485 interface and built-in advanced safety and fault-detection features for integrated control of mobile equipment functions.

OPERATION

The MMS-4820 can be lodged inside any remote control box or panel to make command signals compatible with CANbus networks or RS485 serial lines.

It can be used as a stand-alone controller for Tecnord's Multidrom MLT/FD5 CANbus-configured electro-hydraulic proportional actuators. It can be used as a remote coding card for RS485 serial line connection to other MMS electronic units like Tecnord's Mod. MMS-2218.



FEATURES

- Power supply line is protected against reversed polarity and overvoltage.
- Inputs are protected against short circuits to GND and supply.
- Outputs are protected against short circuits, reversed polarity, over-current and over-temperature.
- 2-wires CANbus or RS485 serial interface.
- Performance level d capability according to ISO 13849, thanks to microprocessor redundancy.
- Electro Magnetic Compatibility (EMC): EN 61000-6-2 (Immunity), EN 61000-6-3 (Emissions).
- Auxiliary +5 V supply for control devices (e.g. potentiometers).

SPECIFICATIONS

Operating voltage:	8.5÷40 VDC
Max current consumption:	0.5 A (no load applied)
Operating temperature:	-25°C / +85°C
Degree of protection:	IP 54
Input impedance:	100 kΩ
Analog inputs (10 bits):	16 (0-5 V)
Typical ctrl pot resistance:	1÷10 kΩ
Digital inputs:	32
High side power outputs:	4 (3.5 A max)
Max current load on all outputs:	5 A
High side signal outputs:	16 (0.7 A max)
Inputs for current feedback:	1
Current output range (PWM):	100÷1500 mA
PWM dither frequency:	60÷200 Hz (adjustable)

DIMENSIONS

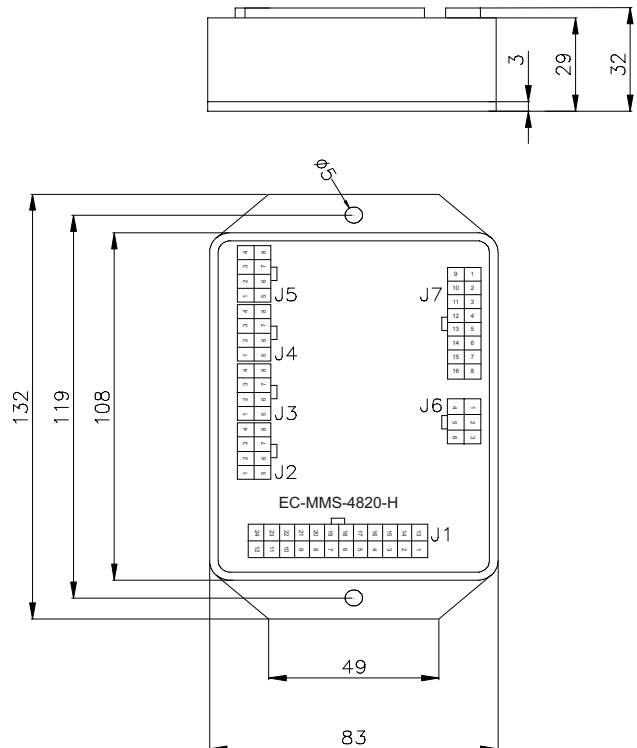

APPLICATIONS

- 12 VDC and 24 VDC systems.
- Control panel management.
- Field-adjustable applications.
- Closed loop systems with electro-hydraulic digital actuators.
- Two or more MMS boards can be interconnected by means of 2-wires RS485 serial lines or CANbus where rotating joints or cable reels are installed.

WARNING: the specifications/application data shown in our catalogs and data sheets are intended only as a general guide for the product described (herein). Any specific application should not be undertaken without independent study, evaluation, and testing for suitability.



4484 Boeing Drive Rockford, IL 61109 • USA • Phone +1 (815) 397-6628 • Fax +1 (815) 397-2526
 mail: delta@delta-power.com • www.delta-power.com



Via Malavolti, 36 • 41122 Modena • ITALY • Phone +39 (059) 254895 • Fax +39 (059) 253512
 mail: tecnord@tecnord.com • www.tecnord.com

EC-MMS-4820-H MACHINE MANAGEMENT SYSTEM

CIRCUIT BOARD PINOUT - WIRING DIAGRAM

Connector type: Molex MINIfit

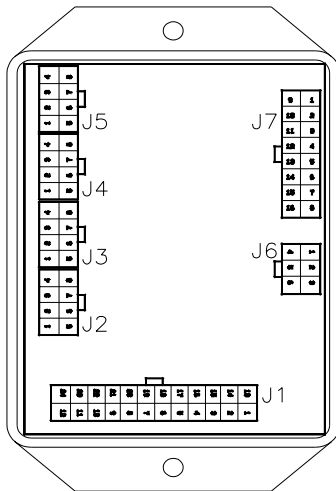

- | | | | |
|--------------|--------------------------------------|-------------|-------------------------------|
| J1 | 1 +V (POWER SUPPLY) | J6 | 1 POWER OUT 1 |
| | 2 5V EXT | | 2 GND |
| | 3 CANH / RS485+ | | 3 PWM CURRENT FEEDBACK |
| | 4 CANL / RS485- | | 4 POWER OUT 2 |
| | 5÷12 ANALOG IN [1÷8] | | 5 POWER OUT 3 |
| | 13 -V (POWER SUPPLY - GND) | | 6 POWER OUT 4 |
| | 14 PROG1 (#1 MICROCONTROLLER) | | |
| | 15 PROG2 (#2 MICROCONTROLLER) | | |
| | 16 RESET | | |
| | 17÷24 ANALOG IN [9÷16] | | |
| J2÷J5 | | J7 | |
| 1÷8 | DIGITAL IN [1÷32] | 1÷16 | SIGNAL OUT [1÷16] |

ADJUSTMENTS

MMS controllers have a customized firmware to fulfill machine functions. A customized calibration tool is available to set main working parameters.



APPLICATION EXAMPLE

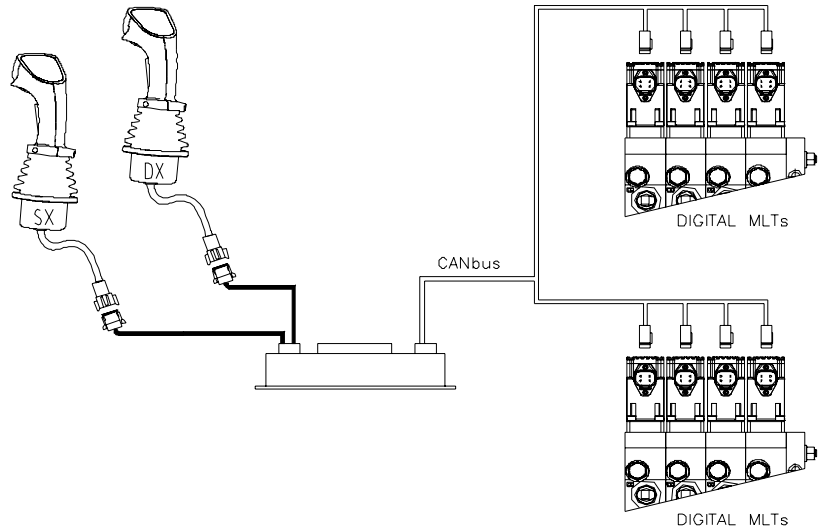

Electro-hydraulic system with MLT digital actuators controlled via 2-wires CANbus line.

ORDERING INFORMATION

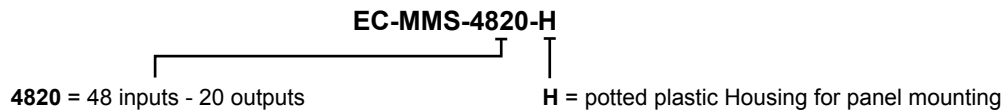

W 3 / 2016

WARNING: the specifications/application data shown in our catalogs and data sheets are intended only as a general guide for the product described (herein). Any specific application should not be undertaken without independent study, evaluation, and testing for suitability.



4484 Boeing Drive Rockford, IL 61109 • USA • Phone +1 (815) 397-6628 • Fax +1 (815) 397-2526
 mail: delta@delta-power.com • www.delta-power.com



Via Malavolti, 36 • 41122 Modena • ITALY • Phone +39 (059) 254895 • Fax +39 (059) 253512
 mail: tecnord@tecnord.com • www.tecnord.com

EC-MMS-0713-H MACHINE MANAGEMENT SYSTEM**DESCRIPTION**

MMS (Machine Management System) controller with built-in advanced driving and fault-detection features to be used as a stand-alone unit or in connection with other CANbus units (e.g. joysticks, MLTs, radio, other MMS).

OPERATION

EC-MMS-0713 can be used as a stand-alone controller for applications with a single PWM or dual proportional manifolds where the functions are operated in meter-in configuration. Its CANbus interface allows it to be used as a part of complex CAN networks e.g. equipped with radio systems. EC-MMS-0713 is provided with display and push-buttons to configure the control characteristics (Imin/lmax, ramps, deadbands, dither) of its PWM output channels.

FEATURES

- Power supply line is protected against reversed polarity and overvoltage.
- Inputs are protected against short circuits to GND and supply.
- Outputs are protected against short circuits, over-current and over-temperature.
- CANbus (CAN 2.0B) interface
- Internal measurement of battery voltage.
- The current in the proportional solenoids is independent of change in the coil resistance and supply voltage variations.
- Especially designed for applications with manifolds in meter-in configuration (single or dual proportional).

**SPECIFICATIONS**

Operating voltage:	8.5÷32 VDC
Max current consumption:	0.25 A (no load applied)
Operating temperature:	-25°C / +85°C
Degree of protection:	IP 65 (with housing)
Analogue inputs:	1, 10-bits resolution
Analogue input type:	0÷20 mA or 0÷5 V selectable by sw (HW option 0÷10 V)
Digital inputs:	6
Input impedance:	100kΩ (internal pull-down)
Max current load on all outputs:	10 A
High Side power outputs:	13 (3.5A max each) (HW option: 14-one digital input not available)
Current output range (PWM):	3 A
Available current feedbacks:	2 (on the high side) (HW option: 4)

APPLICATIONS

- 12 VDC and 24 VDC systems.
- For hand held terminal cable/radio applications.
- Field - adjustable applications.
- Machine management systems based on CANbus.

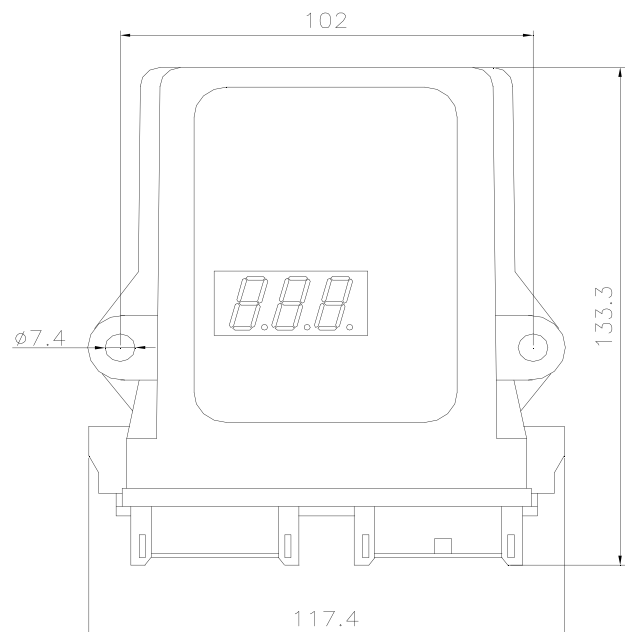
DIMENSIONS

WARNING: the specifications/application data shown in our catalogs and data sheets are intended only as a general guide for the product described (herein). Any specific application should not be undertaken without independent study, evaluation, and testing for suitability.



4484 Boeing Drive Rockford, IL 61109 • USA • Phone +1 (815) 397-6628 • Fax +1 (815) 397-2526
mail: delta@delta-power.com • www.delta-power.com

TECNORD

Via Malavolti, 36 • 41122 Modena • ITALY • Phone +39 (059) 254895 • Fax +39 (059) 253512
mail: tecnord@tecnord.com • www.tecnord.com

EC-MMS-0713-H MACHINE MANAGEMENT SYSTEM

CIRCUIT BOARD PINOUT - WIRING DIAGRAM

Connector type: Deutsch - DTM12

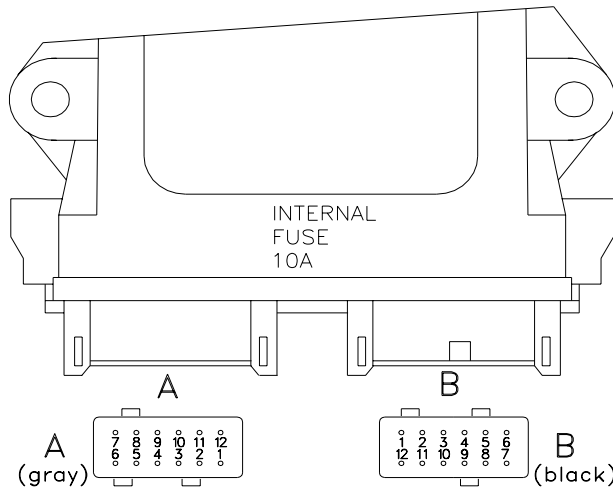

A (GREY)

- 1 DI1 (DIGITAL INPUT)
- 2 EVP1 (HS OUTPUT WITH CURRENT FEEDBACK)
- 3 -V (POWER SUPPLY - GND)
- 4 EVP2 (HS OUTPUT WITH CURRENT FEEDBACK)
- 5 HS11 (HIGH SIDE OUTPUT)
- 6 +V (POWER SUPPLY - POSITIVE)
- 7 HS1 (HIGH SIDE OUTPUT)
- 8 HS2 (HIGH SIDE OUTPUT)
- 9 HS3 (HIGH SIDE OUTPUT)
- 10 HS4 (HIGH SIDE OUTPUT)
- 11 HS5 (HIGH SIDE OUTPUT)
- 12 HS6 (HIGH SIDE OUTPUT)

B (BLACK)

- 1 HS7 (HIGH SIDE OUTPUT)
- 2 HS8 (HIGH SIDE OUTPUT)
- 3 DI2 (DIGITAL INPUT)
- 4 DI3 (DIGITAL INPUT)
- 5 HS9 (HIGH SIDE OUTPUT)
- 6 HS10 (HIGH SIDE OUTPUT)
- 7 CAN HIGH
- 8 CAN LOW
- 9 AIN (ANALOGUE INPUT)
- 10 DI4 (DIGITAL INPUT)
- 11 DI5 (DIGITAL INPUT)
- 12 DI6 (DIGITAL INPUT)

ADJUSTMENTS

Adjustments through integrated display and pushbuttons



APPLICATION EXAMPLE

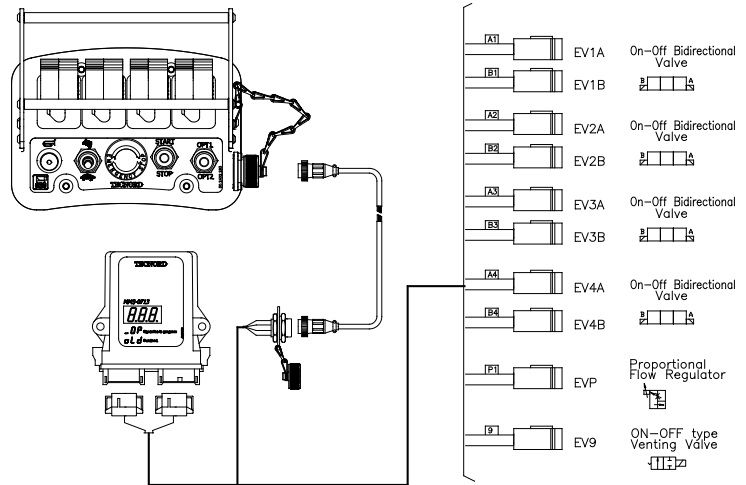

One MMS connected to a portable control unit through a CANbus line. Radio connection available.

ORDERING INFORMATION

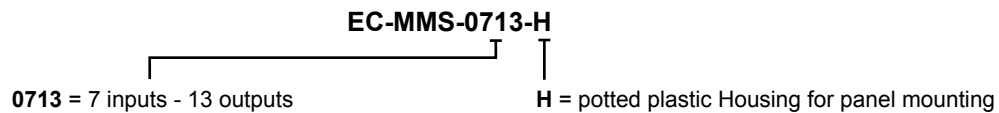

W 3 / 2016

WARNING: the specifications/application data shown in our catalogs and data sheets are intended only as a general guide for the product described (herein). Any specific application should not be undertaken without independent study, evaluation, and testing for suitability.



4484 Boeing Drive Rockford, IL 61109 • USA • Phone +1 (815) 397-6628 • Fax +1 (815) 397-2526
mail: delta@delta-power.com • www.delta-power.com



Via Malavolti, 36 • 41122 Modena • ITALY • Phone +39 (059) 254895 • Fax +39 (059) 253512
mail: tecnord@tecnord.com • www.tecnord.com

EC-MMS-6252-H MACHINE MANAGEMENT SYSTEM CONTROLLER**DESCRIPTION**

MMS (Machine Management System) controller with built-in advanced safety and fault-detection features for integrated control of a high number of functions in mobile equipment applications.

OPERATION

It is normally used as the main control unit in a complete machine management system. Two microprocessors and advanced diagnostics for safety applications. CANbus communication. Serial connection for software download.

FEATURES

- Robust metal enclosure and complete potting.
- Power supply line is protected against reversed polarity and overvoltage.
- Inputs are protected against short circuits to GND and supply.
- Outputs are protected against short circuits, reversed polarity, over-current and over-temperature.
- Dual microprocessor for advanced diagnostics capability.
- Serial communication ports: CANbus, RS485, RS232.
- Optional add-on inclinometer.
- +5 V auxiliary power supply for external control devices.
- Performance level d capability according to ISO 13849, thanks to redundant microcontroller and embedded diagnostics.
- Electro Magnetic Compatibility (EMC): EN 61000-6-2 (Immunity), EN 61000-6-3 (Emissions).

**SPECIFICATIONS**

Operating voltage:	8.5÷32 VDC
Max current consumption:	400 mA (no load applied)
Operating temperature:	-25°C / +85°C
Degree of protection:	IP 67
Input impedance:	100 kΩ
Analog inputs (10 bits):	16 (0-5 V) 6 (0-20 mA)
Typical ctrl pot resistance:	1÷10 kΩ
High side power outputs:	8 (5 A max) 28 (3.5 A max)
High side signal outputs:	10 (0.7 A max)
Digital inputs:	40
Max current load on all outputs:	16 A
Inputs for current feedback:	4
Current output range (PWM):	100÷1600 mA
Analog voltage outputs:	6 (0-5 V)

APPLICATIONS

- 12 VDC and 24 VDC systems.
- Main ECU for aerial platforms, cranes, telehandlers, agric. machines.
- Field-adjustable applications.
- Two or more MMS boards can be interconnected by means of 2-wires RS485 serial lines or CANbus.

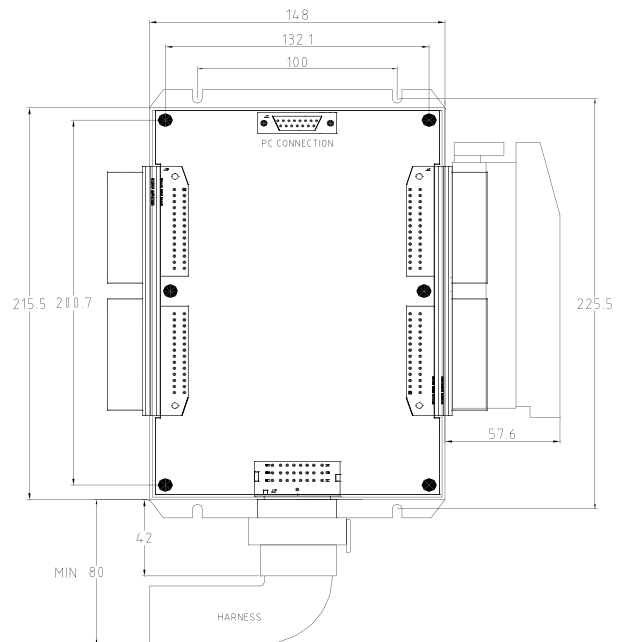
DIMENSIONS

Stainless steel enclosure completely potted.

WARNING: the specifications/application data shown in our catalogs and data sheets are intended only as a general guide for the product described (herein). Any specific application should not be undertaken without independent study, evaluation, and testing for suitability.



4484 Boeing Drive Rockford, IL 61109 • USA • Phone +1 (815) 397-6628 • Fax +1 (815) 397-2526
mail: delta@delta-power.com • www.delta-power.com

TECNORD

Via Malavolti, 36 • 41122 Modena • ITALY • Phone +39 (059) 254895 • Fax +39 (059) 253512
mail: tecnord@tecnord.com • www.tecnord.com

EC-MMS-6252-H MACHINE MANAGEMENT SYSTEM CONTROLLER

CIRCUIT BOARD PINOUT - WIRING DIAGRAM

Main Connectors type: SICMA2/DCS1 (56 poles)
Auxiliary connector type: SICMA2 (24 poles)
PC connector type: DB15 female

- J3**
- 1 CAN BUS
 - 4 ANALOG INPUTS (0+20 MA)
 - 8 ANALOG INPUTS (0+5 V)
 - 24 ANALOG INPUTS
 - 10 DIGITAL OUTPUTS (0.7 A)
 - 1 RS485
 - 2 +5 V AUX
 - 2 +VBATT
 - 2 GND

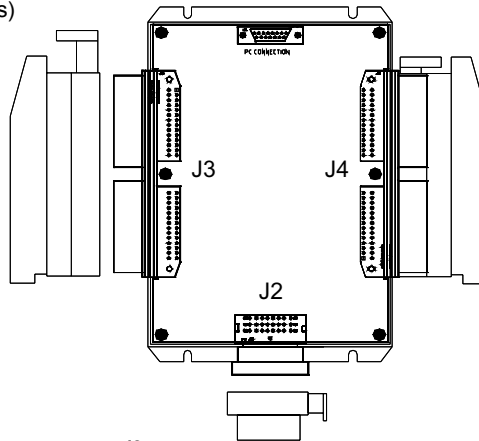

- J4**
- 2 CAN BUS
 - 2 ANALOG INPUTS (0+20 MA)
 - 2 ANALOG INPUTS (0+5 V)
 - 16 DIGITAL INPUTS
 - 18 DIGITAL OUTPUTS (3.5 A)
 - 8 DIGITAL OUTPUTS (5 A)
 - 4 CURRENT FEEDBACKS
 - 2 GND

- J2**
- 6 ANALOG INPUTS (0+5 V)
 - 10 DIGITAL OUTPUTS (3.5 A)
 - 6 ANALOG OUTPUTS (0+5 V)
 - 2 GND

For wiring schematics consult factory.

ADJUSTMENTS

MMS controllers have a customized firmware to fulfill machine functions. A customized calibration tool is available to set main working parameters.



Ask for: PC calibration tool (see page EC44)

APPLICATION EXAMPLE

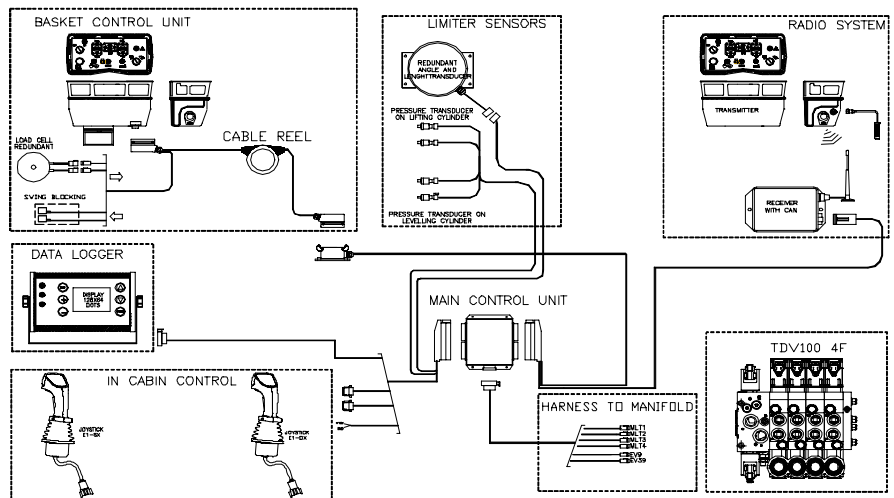

ORDERING INFORMATION

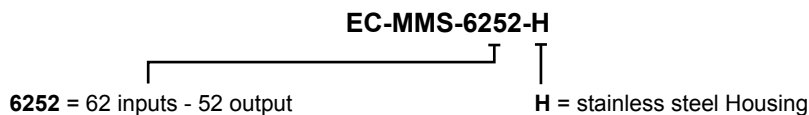

Two configuration available:
Standard (2 main connectors)
Full (all connectors)

W 3 / 2016

WARNING: the specifications/application data shown in our catalogs and data sheets are intended only as a general guide for the product described (herein). Any specific application should not be undertaken without independent study, evaluation, and testing for suitability.



4484 Boeing Drive Rockford, IL 61109 • USA • Phone +1 (815) 397-6628 • Fax +1 (815) 397-2526
 mail: delta@delta-power.com • www.delta-power.com



Via Malavolti, 36 • 41122 Modena • ITALY • Phone +39 (059) 254895 • Fax +39 (059) 253512
 mail: tecnord@tecnord.com • www.tecnord.com

WARNING: *the specifications/application data shown in our catalogs and data sheets are intended only as a general guide for the product described (herein). Any specific application should not be undertaken without independent study, evaluation, and testing for suitability.*



4484 Boeing Drive Rockford, IL 61109 • USA • Phone +1 (815) 397-6628 • Fax +1 (815) 397-2526
mail: delta@delta-power.com • www.delta-power.com



Via Malavolti, 36 • 41122 Modena • ITALY • Phone +39 (059) 254895 • Fax +39 (059) 253512
mail: tecnord@tecnord.com • www.tecnord.com

GRAPHIC DISPLAY UNITS

MODEL	DESCRIPTION	PAGE
EC-VIS-G-D128X64-P	Graphic color display 128x64	EC34
EC-VIS-G-D128x64-M-C	Graphic display 128x64 dots (192 kB eeprom)	EC36
EC-VIS-GC-P480x272-S	Graphic color display 480x272 pixels (64 kB eeprom)	EC38

W 3 / 2016

WARNING: the specifications/application data shown in our catalogs and data sheets are intended only as a general guide for the product described (herein). Any specific application should not be undertaken without independent study, evaluation, and testing for suitability.



Delta Power Company

4484 Boeing Drive Rockford, IL 61109 • USA • Phone +1 (815) 397-6628 • Fax +1 (815) 397-2526
 mail: delta@delta-power.com • www.delta-power.com

TECNORD

Via Malavolti, 36 • 41122 Modena • ITALY • Phone +39 (059) 254895 • Fax +39 (059) 253512
 mail: tecnord@tecnord.com • www.tecnord.com

EC-VIS-G-D128X64-P GRAPHIC DISPLAY UNIT**DESCRIPTION**

Graphic Display Unit to be used as operator's interface in complex Machine Management Systems.

FEATURES

- Compact control unit to be fixed inside a cabin.
- Robust suction cup on the rear.
- CANbus connection.
- Graphic display 128 x 64 dots backlighted.

MECHANICAL / ENVIRONMENTAL SPECIFICATIONS

Dimensions:	131 x 100.5 x 20.8 mm
Housing:	Plastic body Membrane keypad
Operating temperature:	-25 / 85°C
Degree of protection:	IP 67
Connector:	Molex Minifit 20 poles

ELECTRICAL SPECIFICATIONS**Display**

Type and size:	graphic
Resolution:	128 x 64 dot-matrix
Viewing area:	50 x 25 mm
Backlight:	led
Backlight color:	white
Viewing angle range:	40°

ELECTRONIC CONTROL UNIT

Operating voltage:	8.5÷30 VDC
Communication interfaces:	CANbus SAE J1939
Analog inputs (10 bits):	4 (0-5 V)
Digital inputs:	5
High side power outputs:	4 (3.5 A max each)
Internal inputs:	
for current feedback:	4
PWM output current range:	100 - 1500 mA
Membrane keypad with:	
Pushbuttons:	9
SMD leds:	9
Control potentiometer on the top:	1

APPLICATIONS

- 12 VDC and 24 VDC systems.
- Service/Maintenance Tool.
- Diagnostic/Configuration unit for Hedgecutters.
- In-cab terminal.

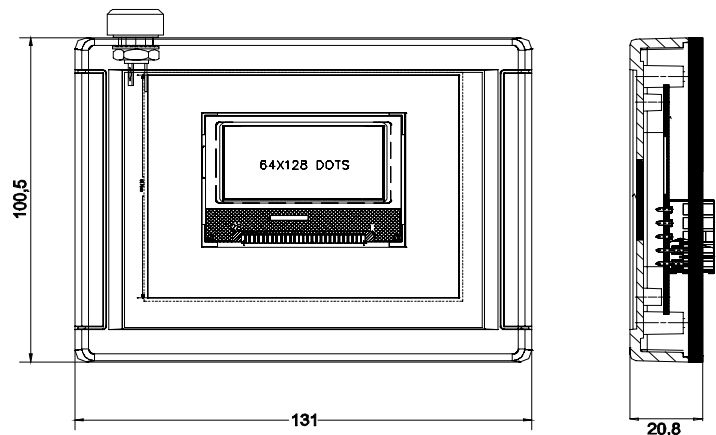
**DIMENSIONS**

WARNING: the specifications/application data shown in our catalogs and data sheets are intended only as a general guide for the product described (herein). Any specific application should not be undertaken without independent study, evaluation, and testing for suitability.



4484 Boeing Drive Rockford, IL 61109 • USA • Phone +1 (815) 397-6628 • Fax +1 (815) 397-2526
mail: delta@delta-power.com • www.delta-power.com

TECNORD

Via Malavolti, 36 • 41122 Modena • ITALY • Phone +39 (059) 254895 • Fax +39 (059) 253512
mail: tecnord@tecnord.com • www.tecnord.com

EC-VIS-G-D128X64-P GRAPHIC DISPLAY UNIT

CIRCUIT BOARD PINOUT - WIRING DIAGRAM

Connector type: Molex Minifit

- | | |
|--------------------|-----------------|
| 1 -V (POWER - GND) | 11 +V (POWER) |
| 2 CAN H | 12 CAN L |
| 3 ANALOG IN 2 | 13 ANALOG IN 3 |
| 4 ANALOG IN 0 | 14 ANALOG IN 1 |
| 5 DIGITAL IN 2 | 15 DIGITAL IN 3 |
| 6 DIGITAL IN 0 | 16 DIGITAL IN 1 |
| 7 DIGITAL IN 4 | 17 OUT P0 |
| 8 OUT P1 | 18 OUT P2 |
| 9 N.C. | 19 OUT P3 |
| 10 N.C. | 20 +5 V EXT |

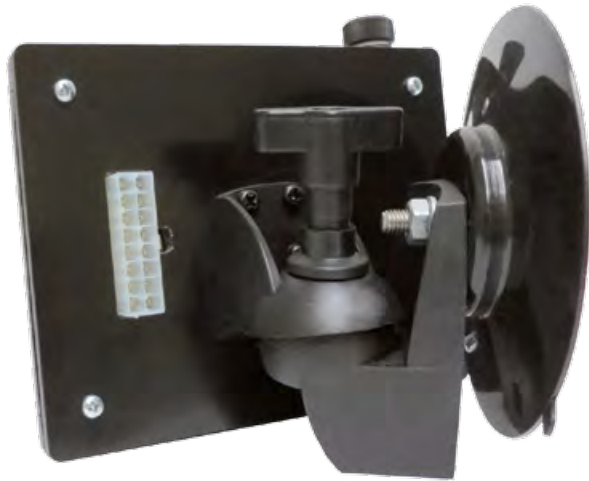

APPLICATION EXAMPLE

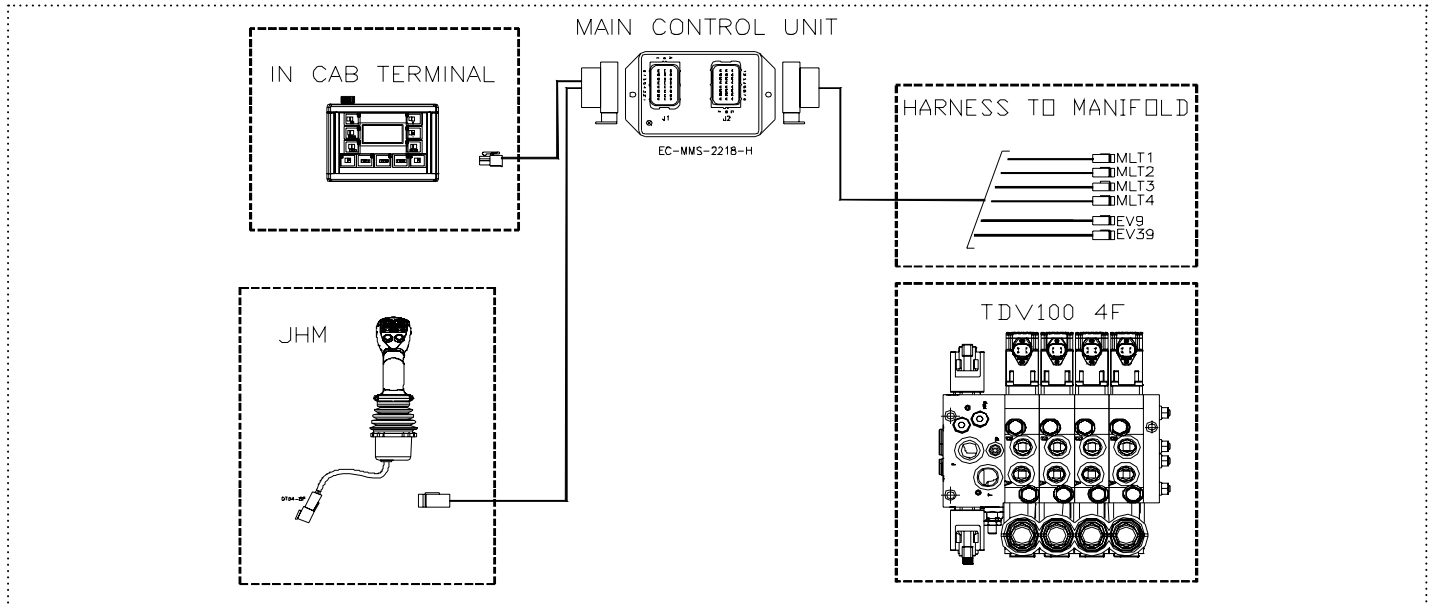

ORDERING INFORMATION

EC-VIS-G-D128X64-P

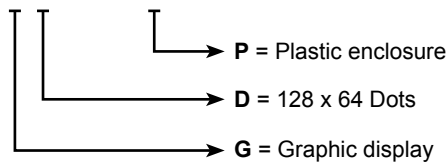

W 3 / 2016

WARNING: the specifications/application data shown in our catalogs and data sheets are intended only as a general guide for the product described (herein). Any specific application should not be undertaken without independent study, evaluation, and testing for suitability.



4484 Boeing Drive Rockford, IL 61109 • USA • Phone +1 (815) 397-6628 • Fax +1 (815) 397-2526
 mail: delta@delta-power.com • www.delta-power.com



Via Malavolti, 36 • 41122 Modena • ITALY • Phone +39 (059) 254895 • Fax +39 (059) 253512
 mail: tecnord@tecnord.com • www.tecnord.com

EC-VIS-G-D128X64-M-C GRAPHIC DISPLAY UNIT**DESCRIPTION**

Graphic display unit to be used as operator's interface in complex Machine Management Systems.

FEATURES

- RS-232 serial interface.
- 1 CANbus connection.
- Graphic display 128 x 64 dots backlighted.
- Real time clock with calendar.
- Wide data storage memory.

MECHANICAL / ENVIRONMENTAL SPECIFICATIONS

Dimensions:	174 x 108 x 31 mm
Housing:	Metal body Polycarbonate cover
Operating temperature:	-25°C / 85°C
Degree of protection:	IP 67
Connector:	SICMA2, 24 pin

ELECTRICAL SPECIFICATIONS**Display**

Type and size:	graphic
Resolution:	128 x 64 dot-matrix
Viewing area:	62 x 44 mm
Brightness:	8 cd/m ²
Contrast:	8:1
Viewing angle range:	40°

ELECTRONIC CONTROL UNIT

Operating voltage:	8.5÷30 VDC
Communication interfaces:	CANbus ISO11898 RS 232
Analog inputs (10 bits):	8 (0-5 V)
Digital inputs:	1
High side power outputs:	4 (3.5 A max each)
Inputs for current feedback:	2
PWM output current range:	100-1500 mA
Non volatile memory:	192 kB
Backlighted pushbuttons:	standard 6 (max 9)
High efficiency leds:	standard 3 (max 4)

APPLICATIONS

- 12 VDC and 24 VDC systems.
- Load limiter and/or area control systems.
- In-cab terminal.
- Data logger.

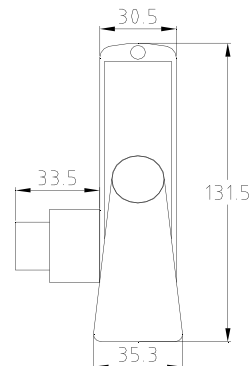
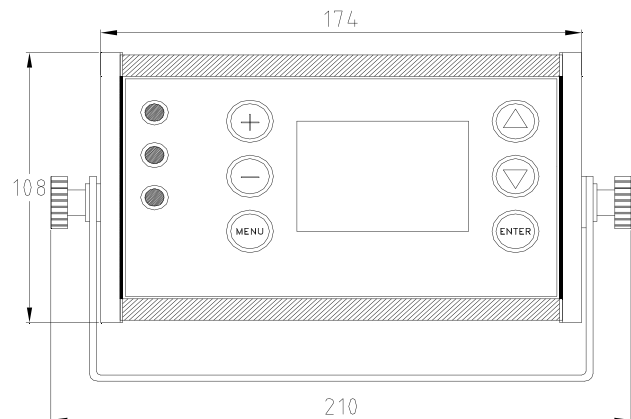
**DIMENSIONS**

WARNING: the specifications/application data shown in our catalogs and data sheets are intended only as a general guide for the product described (herein). Any specific application should not be undertaken without independent study, evaluation, and testing for suitability.



4484 Boeing Drive Rockford, IL 61109 • USA • Phone +1 (815) 397-6628 • Fax +1 (815) 397-2526
mail: delta@delta-power.com • www.delta-power.com

TECNORD

Via Malavolti, 36 • 41122 Modena • ITALY • Phone +39 (059) 254895 • Fax +39 (059) 253512
mail: tecnord@tecnord.com • www.tecnord.com

EC-VIS-G-D128X64-M-C GRAPHIC DISPLAY UNIT

CIRCUIT BOARD PINOUT - WIRING DIAGRAM

Connector type: SICMA2 (24 poles)

A	B	C
1 -V (POWER - GND)	1 +5V EXT	1 +V (POWER)
2 ANALOG IN 1	2 ANALOG IN 0	2 CAN-L
3 ANALOG IN 2	3 ANALOG IN 3	3 CAN-H
4 DIGITAL IN	4 HEATER IN	4 CURRENT FEEDBACK 1
5 ANALOG IN 5	5 ANALOG IN 4	5 CURRENT FEEDBACK 2
6 ANALOG IN 6	6 ANALOG IN 7	6 RS232 TX
7 OUT 1	7 -V (POWER - GND)	7 RS232 RX
8 OUT 0	8 OUT 3	8 OUT 2



APPLICATION EXAMPLE

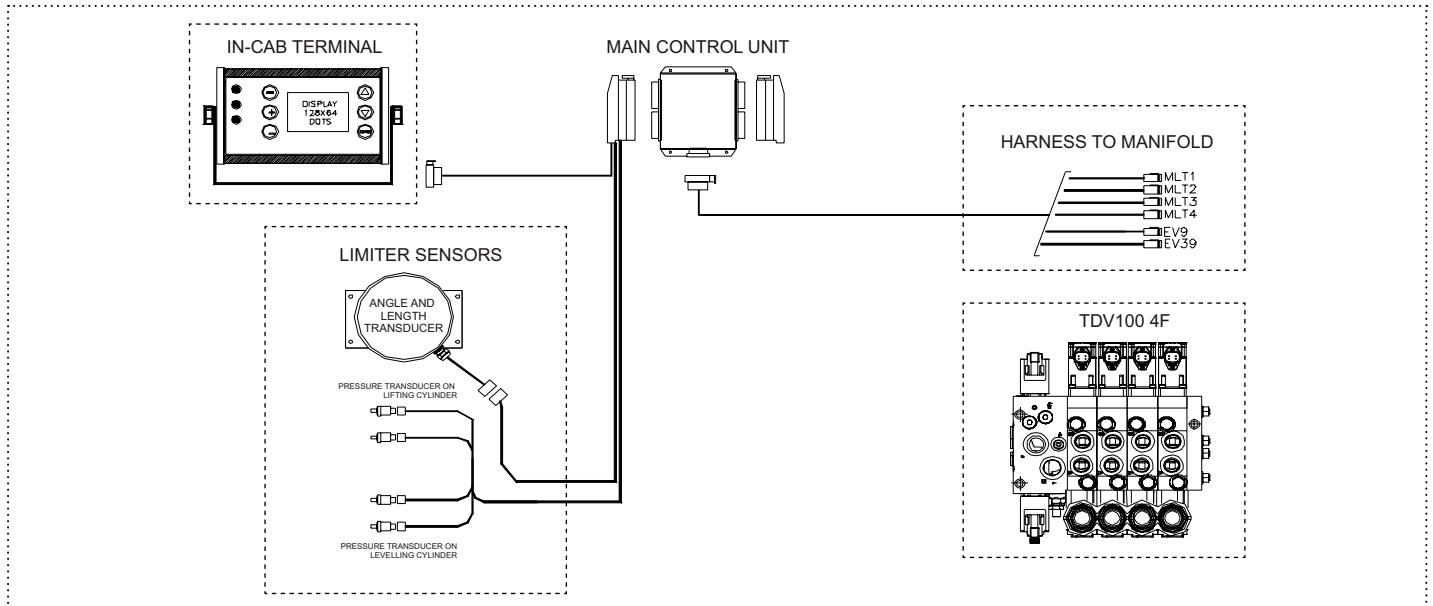

ORDERING INFORMATION

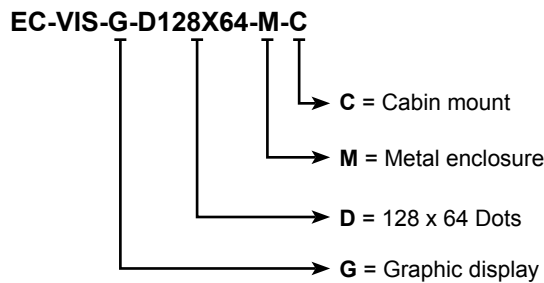

W 3 / 2016

WARNING: the specifications/application data shown in our catalogs and data sheets are intended only as a general guide for the product described (herein). Any specific application should not be undertaken without independent study, evaluation, and testing for suitability.



4484 Boeing Drive Rockford, IL 61109 • USA • Phone +1 (815) 397-6628 • Fax +1 (815) 397-2526
 mail: delta@delta-power.com • www.delta-power.com



Via Malavolti, 36 • 41122 Modena • ITALY • Phone +39 (059) 254895 • Fax +39 (059) 253512
 mail: tecnord@tecnord.com • www.tecnord.com

EC-VIS-GC-P480X272-S GRAPHIC DISPLAY UNIT**DESCRIPTION**

Color graphic display unit.

FEATURES

- Dual-molding plastic-silicon enclosure.
- 4.3" TFT backlighted color display.
- Stand alone or dashboard mount.
- 6 push buttons (backlighted), 6 LEDs.
- CANbus interface.
- Electro Magnetic Compatibility (EMC): EN 61000-6-2 (Immunity)
EN 61000-6-3 (Emissions)
- Auxiliary +5 V supply for external devices (e.g. sensors).

MECHANICAL / ENVIRONMENTAL SPECIFICATIONS

Dimensions:	182 x 117 x 49 mm
Housing:	polycarbonate body soft silicon rubber cover
Operating temperature:	-25°C / 85°C
Degree of protection:	IP 65
Connector:	AMP superseal, 26 pin

ELECTRICAL SPECIFICATIONS**Display**

Type and size:	TFT, 4.3", 16:9
Resolution:	480 x 272 pixels
Viewing area:	95.04 x 53.856 mm
Brightness:	280 cd/m ²
Contrast:	450:1
Viewing angle range:	±70° H, +70/-50° V

ELECTRONIC CONTROL UNIT

Operating voltage:	8+32 VDC
Communication interfaces:	CANbus ISO11898 RS 232 USB
Analog inputs (10 bits):	8 (0-5 V)
Additional features:	real time clock 4 analog inputs
Input impedance:	100 kΩ
Max. current from +5 V auxiliary out:	25 mA

APPLICATIONS

- System diagnostic for heavy duty vehicles.
- Diagnostic/configuration unit for telehandlers.
- Service/maintenance tool.
- Data logger.

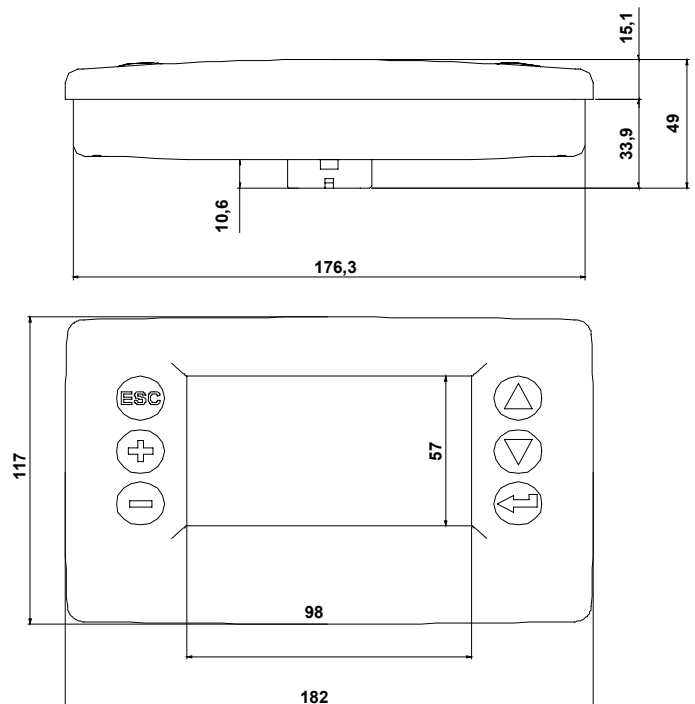
**DIMENSIONS**

WARNING: the specifications/application data shown in our catalogs and data sheets are intended only as a general guide for the product described (herein). Any specific application should not be undertaken without independent study, evaluation, and testing for suitability.

EC-VIS-GC-P480X272-S GRAPHIC DISPLAY UNIT

CIRCUIT BOARD PINOUT - WIRING DIAGRAM

Connector type: AMP Superseal 1.00 mm, 26 pin

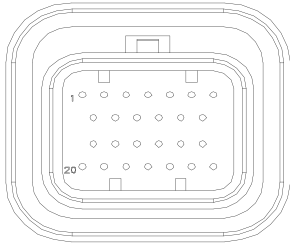

- | | | |
|---------------|---------------------|---------------------|
| 1 ANALOG IN 0 | 10 ANALOG IN 5 | 19 +5 V EXT |
| 2 ANALOG IN 1 | 11 NOT USED | 20 CAN H |
| 3 ANALOG IN 2 | 12 -V (POWER - GND) | 21 CAN L |
| 4 NOT USED | 13 -V (POWER - GND) | 22 -V (POWER - GND) |
| 5 +5 V EXT | 14 RX232 | 23 NOT USED |
| 6 +V (POWER) | 15 TX232 | 24 USB ID |
| 7 +V (POWER) | 16 NOT USED | 25 USB D+ |
| 8 ANALOG IN 3 | 17 NOT USED | 26 USB D- |
| 9 ANALOG IN 4 | 18 NOT USED | |

MOUNTING OPTIONS

Dashboard Mount



Panel cutout of 177 x 112 mm

Cabin Mount



N. 4 Fixing holes for M4 screws at 75 x 50 mm

ORDERING INFORMATION

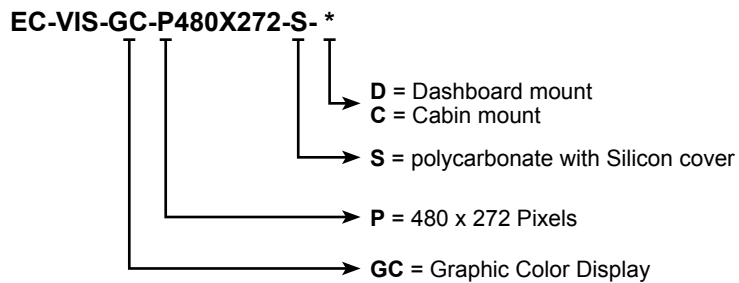

W 3 / 2016

WARNING: the specifications/application data shown in our catalogs and data sheets are intended only as a general guide for the product described (herein). Any specific application should not be undertaken without independent study, evaluation, and testing for suitability.



4484 Boeing Drive Rockford, IL 61109 • USA • Phone +1 (815) 397-6628 • Fax +1 (815) 397-2526
 mail: delta@delta-power.com • www.delta-power.com



Via Malavolti, 36 • 41122 Modena • ITALY • Phone +39 (059) 254895 • Fax +39 (059) 253512
 mail: tecnord@tecnord.com • www.tecnord.com

WARNING: *the specifications/application data shown in our catalogs and data sheets are intended only as a general guide for the product described (herein). Any specific application should not be undertaken without independent study, evaluation, and testing for suitability.*



4484 Boeing Drive Rockford, IL 61109 • USA • Phone +1 (815) 397-6628 • Fax +1 (815) 397-2526
mail: delta@delta-power.com • www.delta-power.com

TECNORD

Via Malavolti, 36 • 41122 Modena • ITALY • Phone +39 (059) 254895 • Fax +39 (059) 253512
mail: tecnord@tecnord.com • www.tecnord.com

ACCESSORIES

MODEL	DESCRIPTION	PAGE
Control unit connection	Connector kits	EC42
Control unit calibration tool	Software calibration tool linking cables	EC44
Cables	Linking Cables	EC45

W 3 / 2016

WARNING: the specifications/application data shown in our catalogs and data sheets are intended only as a general guide for the product described (herein). Any specific application should not be undertaken without independent study, evaluation, and testing for suitability.



4484 Boeing Drive Rockford, IL 61109 • USA • Phone +1 (815) 397-6628 • Fax +1 (815) 397-2526
 mail: delta@delta-power.com • www.delta-power.com

TECNORD

Via Malavolti, 36 • 41122 Modena • ITALY • Phone +39 (059) 254895 • Fax +39 (059) 253512
 mail: tecnord@tecnord.com • www.tecnord.com

CONNECTOR KITS

6 POLES DEUTSCH DT04-6P

Kit includes: female connector, male contacts, secondary lock and fillers
Available for electronic control unit: EC-MMS-1012-H

ORDERING CODE: 13.0310.386

**8 POLES DEUTSCH DT06-8S**

Kit includes: male connector, female contacts, secondary lock and fillers
Available for electronic control unit: EC-PWM-A2-MPC1-H

ORDERING CODE: 13.0310.432

**12 POLES "DEUTSCH DTM06-12SA & DTM06-12SB"**

Kit includes: male connector, female contacts, secondary lock and fillers
Available for electronic control unit: EC-MMS-0713-H

ORDERING CODE: 13.0310.253

**26 POLES AMP SUPERSEAL**

Kit includes: male connector, female contacts
Available for electronic control unit: EC-VIS-GC-P480x272-S

ORDERING CODE: 13.0310.635



WARNING: the specifications/application data shown in our catalogs and data sheets are intended only as a general guide for the product described (herein). Any specific application should not be undertaken without independent study, evaluation, and testing for suitability.



4484 Boeing Drive Rockford, IL 61109 • USA • Phone +1 (815) 397-6628 • Fax +1 (815) 397-2526
 mail: delta@delta-power.com • www.delta-power.com

TECNORD

Via Malavolti, 36 • 41122 Modena • ITALY • Phone +39 (059) 254895 • Fax +39 (059) 253512
 mail: tecnord@tecnord.com • www.tecnord.com

CONNECTOR KITS**24 POLES SICMA BLACK COLOR**

Kit includes: male connector, female contacts, locking cum, fillers

Available for electronic control unit: EC-PWM-P4-MPC2-H; EC-PWM-P8-MPC4-H;
EC-PWM-08-MPC4-H; EC-MMS-1012-H; EC-MMS-2218-H; EC-MMS-1521-H

ORDERING CODE: 13.0310.150

**24 POLES SICMA GREY COLOR**

Kit includes: male connector, female contacts, locking cum, fillers

Available for electronic control unit: EC-MMS-1521-H

ORDERING CODE: 13.0310.634

**24 POLES SICMA BLACK COLOR WITH WIRES 0.8 M LENGTH**

Kit includes: male connector, female contacts, locking cum and wires 0,8 m length

Available for electronic control unit: EC-PWM-P4-MPC2-H; EC-PWM-P8-MPC4-H;
EC-PWM-08-MPC4-H, EC-MMS-1012-H; EC-MMS-2218-H; EC-MMS-1521-H

ORDERING CODE: 13.0310.236

**56 POLES SICMA**

Kit includes: male connector, female contacts, locking cum, cover and fillers

Available for electronic control unit: EC-MMS-6252-H

ORDERING CODE: 13.0310.324

**56 POLES SICMA WITH WIRES 0.8 M LENGTH**

Kit includes: male connector, female contacts, locking cum, cover and fillers

Available for electronic control unit: EC-MMS-6252-H

ORDERING CODE: 13.0310.868



WARNING: the specifications/application data shown in our catalogs and data sheets are intended only as a general guide for the product described (herein). Any specific application should not be undertaken without independent study, evaluation, and testing for suitability.

W 3 / 2016



4484 Boeing Drive Rockford, IL 61109 • USA • Phone +1 (815) 397-6628 • Fax +1 (815) 397-2526
mail: delta@delta-power.com • www.delta-power.com

TECNORD

Via Malavolti, 36 • 41122 Modena • ITALY • Phone +39 (059) 254895 • Fax +39 (059) 253512
mail: tecnord@tecnord.com • www.tecnord.com

CALIBRATION TOOL

TECNORD SOFTWARE ELECTRONIC UNITS CALIBRATION TOOL

Tecnord electronic control units are supplied with operation parameters standard programming, which satisfies most applications. For special application SCT calibration software allows some of the parameters for proportional solenoid valve control to be modified via computer; for example the minimum and maximum current or ramp up and ramp down parameters may be defined. The linking cable shown in the following page (optional, to be ordered separately) is necessary for the computer connection.



SOFTWARE
INSTALLATION

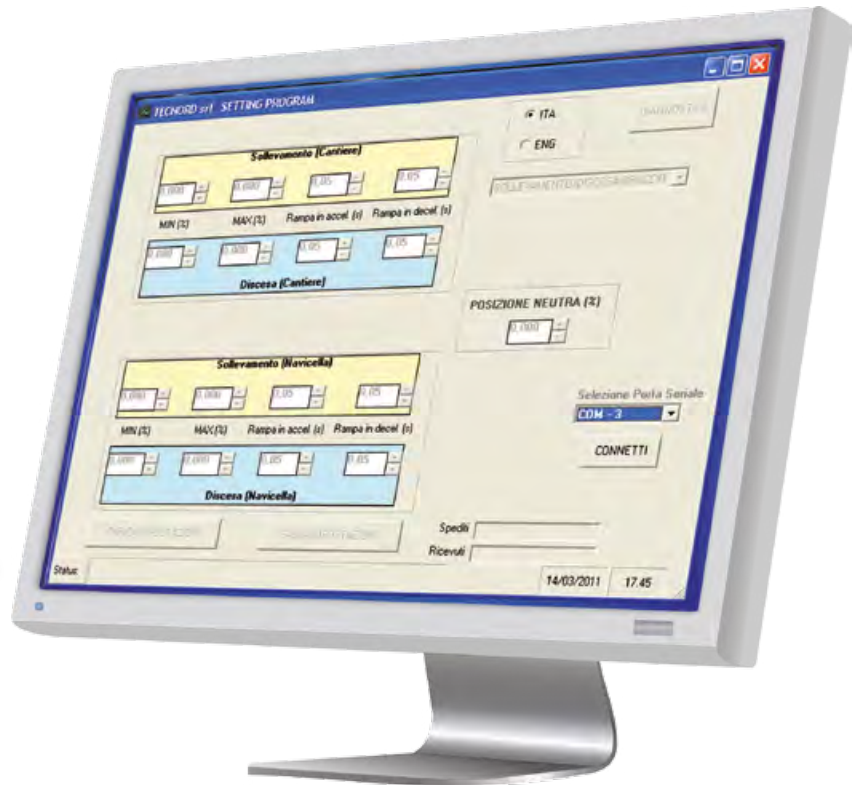

MINIMUM SYSTEM REQUIREMENTS

- Windows XP® operating system or higher.
- Intel® Pentium processor.
- 32 Mb RAM.
- CD player unit.
- Connecting through a standard RS232 serial port, DB9 connection; alternatively, a USB-RS232 converter can be used.

PROGRAM INSTALLATION

To install the SCT software onto a personal computer, simply execute the file *setup.exe*.

WARNING: the specifications/application data shown in our catalogs and data sheets are intended only as a general guide for the product described (herein). Any specific application should not be undertaken without independent study, evaluation, and testing for suitability.

 Delta Power Company

4484 Boeing Drive Rockford, IL 61109 • USA • Phone +1 (815) 397-6628 • Fax +1 (815) 397-2526
mail: delta@delta-power.com • www.delta-power.com

TECNORD

Via Malavolti, 36 • 41122 Modena • ITALY • Phone +39 (059) 254895 • Fax +39 (059) 253512
mail: tecnord@tecnord.com • www.tecnord.com

LINKING CABLES

AMPSEAL-DB9 CABLE ADAPTER (with software calibration tool)

Available for electronic control unit: EC-PWM-P4; EC-PWM-P8; EC-MMS-1012-H

ORDERING CODE: 20.1001.026/A**DEUTSCH-DB9 LINKING CABLE (with customized software calibration tool)**

Available for electronic control unit: EC-MMS-2218-H

ORDERING CODE: 21.0801.031**DB15-DB9 LINKING CABLE (with software calibration tool)**

Available for electronic control unit: EC-MMS-6252-H

ORDERING CODE: 21.0801.053**RS232 - USB CONVERTER**

It allows Tecnorm electronic control units to personal computer connection when the latter is unprovided of serial port; for installation follow the instruction enclosed with the converter

ORDERING CODE: 21.0801.039**CAN - USB CONVERTER**

It allows Tecnorm CAN joysticks to Personal Computer connection with a USB port; for installation follow the instruction enclosed with the interface device

ORDERING CODE: 21.0801.040

WARNING: *the specifications/application data shown in our catalogs and data sheets are intended only as a general guide for the product described (herein). Any specific application should not be undertaken without independent study, evaluation, and testing for suitability.*



4484 Boeing Drive Rockford, IL 61109 • USA • Phone +1 (815) 397-6628 • Fax +1 (815) 397-2526
mail: delta@delta-power.com • www.delta-power.com

TECNORD

Via Malavolti, 36 • 41122 Modena • ITALY • Phone +39 (059) 254895 • Fax +39 (059) 253512
mail: tecnord@tecnord.com • www.tecnord.com