Standard Powerpack – modular build vertical HPS type



Description

The HPS Standard construction power packs are designed to utilise a standard range of modular components. This offers a power pack that can be easily specified and maintained.

Design

- Steel Tank 16, 30, 55, 75, 100 & 180 Litre
- Aluminium Gear pumps
- Pressures to 250 bar
- Flow rates to 100 litres/minute
- Suction filter 90 micron
- Return filter 25 micron
- Submerged Pump
- Cetop subplate options
- 1 phase to 3kW
- 3 phase to 30kW

Quality

- 100% functional testing
- Tanks with painted finish
- Motors IEC frame B5 IP55
- Supplied with C of C

Ordering Code

HPS - S - G4 - 6C - V - P - 3 - 16C - D - XXXX

Type

Motor type

S = 240V 1ph
T = 415V 3ph
H = 110V 1ph
N = None

Motor power

D = 0.55kW
E = 0.75kW
F = 1.1kW
G = 1.5kW
H = 2.2kW
I = 3.0kW
J = 4.0kW
K = 5.5kW
L = 7.5kW
M = 11kW
N = 15kW
O = 18.5kW
P = 22kW
Q = 30kW

Pump size

See page 4

Orientation

V = vertical

Hydraproducts build number

Accessories – optional

Oil Low Level switch = L
Thermostat = T
Air blast Cooler = A
Oil/Water Cooler = W
Hand Pump = P
Drain port boss ½”BSP = D
Heater = H
None = N

Type of Reservoir

16 Litre = 16C
30 Litre = 30C
55 Litre = 55C
75 Litre = 75C
100 Litre = 100C
180 Litre = 180C

Cetop plate

NG6 cetop03 (40lpm max) = 3
NG10 cetop05 (80lpm max) = 5
None = N

Manifold plate

P-T BSP Ports with Relief Valve = P
Bespoke manifold system = X

Validity of all specifications and order codes must be confirmed with Hydraproducts sales department

Motor Selection

Motor power	Frame	Height “D”
D = 0.55kW	80a	250mm
E = 0.75kW	80b	250mm
F = 1.1kW	90S	264mm
G = 1.5kW	90L	288mm – maximum of 110V 1phase
H = 2.2kW	100La	322mm
I = 3.0kW	100Lb	322mm - maximum of 240V 1phase
J = 4.0kW	112M	353mm
K = 5.5kW	132S	380mm
L = 7.5kW	132Ma	421mm
M = 11kW	160M	496mm
N = 15kW	160L	496mm
O = 18.5kW	180M	539mm
P = 22kW	180L	539mm
Q = 30kW	200L	577mm

Power pack overview

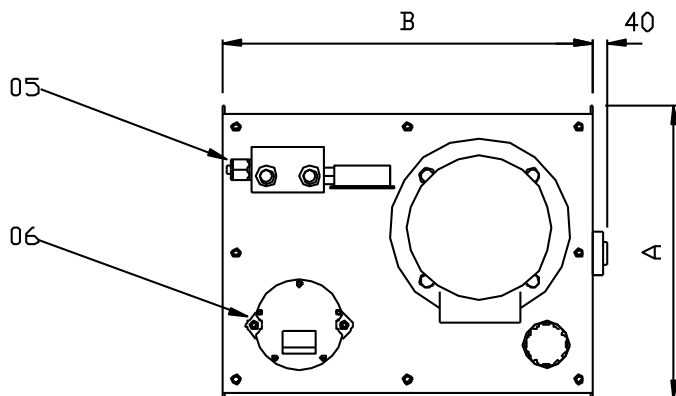

- 01 Motor
- 02 Pump
- 03 Bellhousing and coupling
- 04 Suction filter
- 05 Manifold block
- 06 Return Filter & Indicator
- 07 Pressure Gauge
- 08 Gauge Isolator
- 09 Tank
- 10 Level Gauge
- 11 Filler Breather

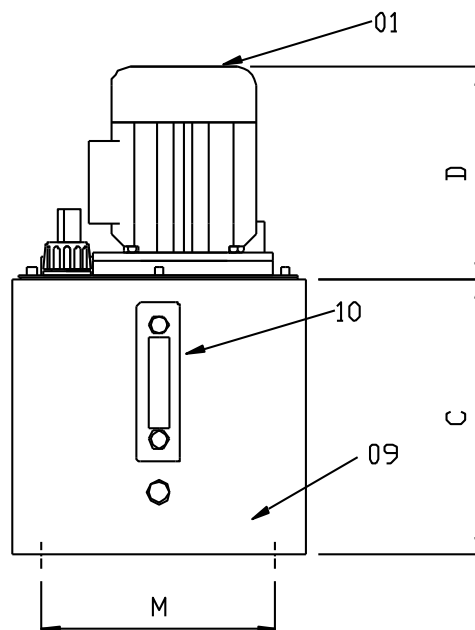
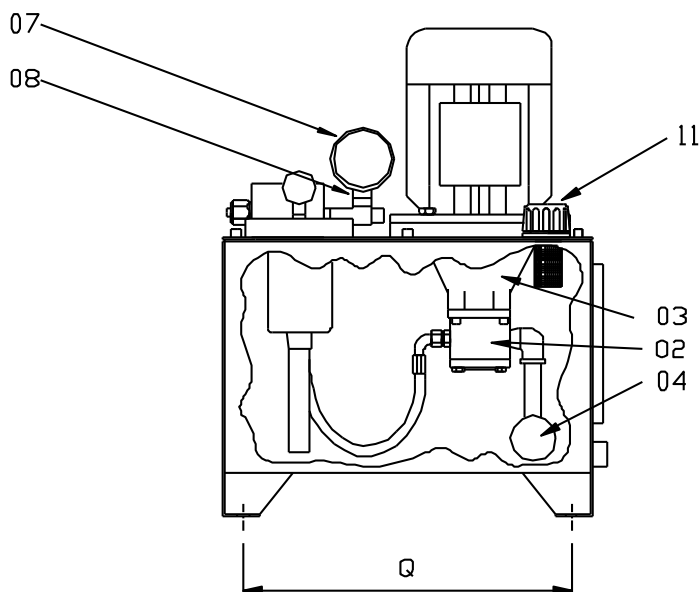

Tank	A	B	C	Q	M	Pump size cc (litre per minute)	Motor size
16 litre	410 mm	325 mm	310 mm	364 mm	270 mm	from 1cc (1.45 lpm) to 9.8cc (14.2 lpm)	from 0.55kW to 1.5kW
30 litre	470 mm	375 mm	340 mm	428 mm	312 mm	from 3.15cc (4.5 lpm) to 14cc (20.3 lpm)	from 1.1kW to 4kW
55 litre	600 mm	470 mm	370 mm	548 mm	401mm	from 6.3cc (9.1 lpm) to 22cc (31 lpm)	from 2.2kW to 7.5kW
75 litre	600 mm	470 mm	460 mm	548 mm	401 mm	from 12cc (17.4 lpm) to 32cc (46 lpm)	from 4kW to 7.5kW
100 litre	675 mm	520 mm	510 mm	625 mm	455 mm	from 12cc (17.4 lpm) to 36cc (52 lpm)	from 4kW to 22kW
180 litre	805 mm	620 mm	560 mm	755 mm	555 mm	from 20cc (29 lpm) to 60cc (87 lpm)	from 7.5kW to 30kW

Pump Selection

Pump No,	Displacement cc/rev	Flow at 1450rpm litres/minute	Max Pressure bar
1C	1	1.45	250
2C	1.25	1.8	250
3C	1.6	2.3	250
4C	2.0	2.9	250
5C	2.5	3.6	250
6C	3.15	4.5	250
7C	3.65	5.3	250
8C	4.2	6.1	250
9C	5.0	7.2	250
10C	6.1	8.8	200
11V	9.8	14.2	180
20C	6.3	9.1	250
21C	8.2	11.8	250
22C	10	14.5	250
23C	11.3	16.4	250
24C	12	17.4	250
25C	14	20.3	250
26C	15	21.7	250
27C	16	23.2	250
28C	19	27.5	200
29C	22	31	180
30C	20	29	250
31C	25	36	250
32C	28	40	250
33C	32	46	250
34C	36	56	250
35C	42	60	230
36C	46	66	230
37C	50	72	200
38C	55	79	200
39C	60	87	180

Hydraulic Circuit

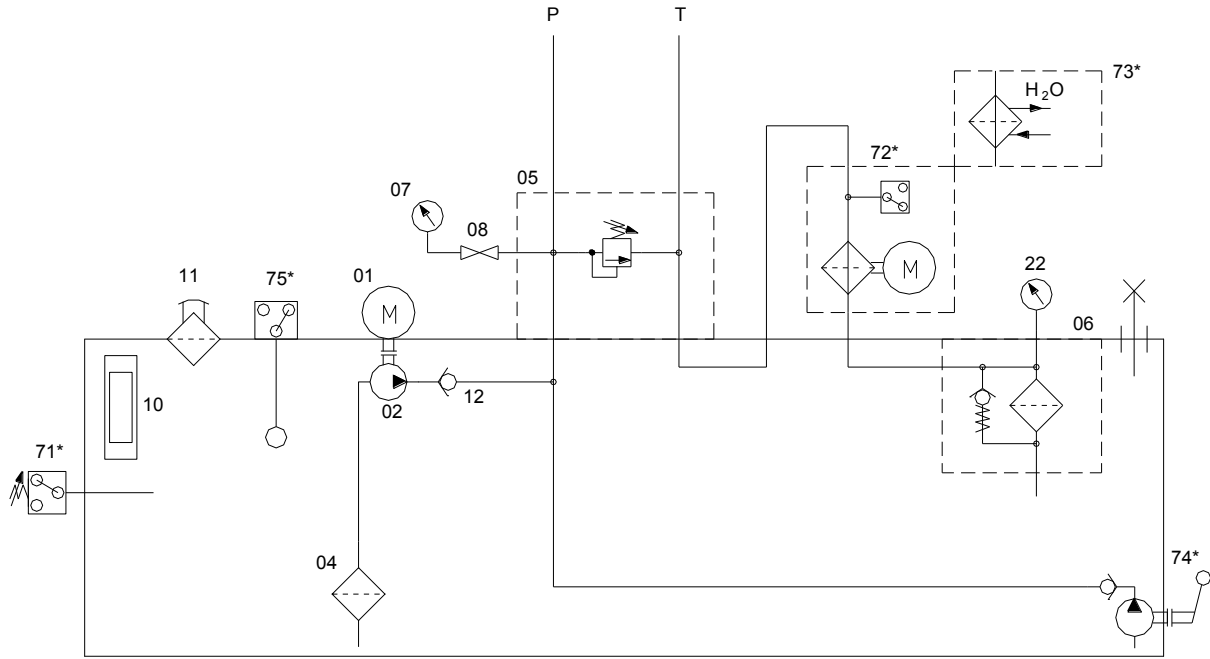

* - OPTIONAL

PUMP – MOTOR – TANK SELECTION

PUMP GROUP 1											PUMP GROUP 2											PUMP GROUP 3											cc/rev FLOW lpm	MOTOR (Kw)	TANK SIZES AVAILABLE (LITRES)					
1	1.25	1.6	2.0	2.5	3.15	3.65	4.2	5	6.1	9.8	6.2	8	10	11	12	14	15	16	19	22	20	25	28	32	36	42	46	50	55	60										
1.5	1.8	2.3	2.9	3.6	4.6	5.3	6.1	7.3	8.8	14.5	9.1	11.9	14.5	16.4	17.4	20.3	21.8	23.2	27.6	31.9	20.9	36.3	40.6	46.4	52.5	60.9	66.7	72.5	79.8	87	0.55	16								
209	167	130	104	83	66	57	50	42	34	21	45	35	28	25	24	20	19	18	15	13											0.75	16								
250	228	178	142	114	90	78	68	57	47	29	66	51	42	37	35	30	28	26	22	19											1.1	16	30							
	250	250	209	167	132	114	99	83	68	43	90	69	57	50	47	41	38	36	30	26											1.5	16	30							
		250	228	181	156	135	114	93	58	132	102	83	74	70	60	56	52	44	38	42	33	30	26	23	20	18	17	15	14	2.2	30	55								
			250	250	229	199	167	137	85	181	139	114	101	95	81	76	71	60	52	57	46	41	36	32	27	25	23	21	19	3	30	55								
				250	250	228	187	116	241	185	152	134	126	108	101	95	80	69	76	61	54	47	42	36	33	30	28	25	4	30	55	75	100							
					250	200	155	250	250	209	185	174	149	139	130	110	95	104	83	75	65	58	50	45	42	38	35	5.5	55	75	100									
						180			250	250	237	203	190	178	150	129	142	114	102	89	79	68	62	57	52	47	7.5	55	75	100	180									
																				209	167	149	130	116	99	91	83	76	70	11				100	180					
																				250	228	203	178	158	135	124	114	103	95	15				100	180					
																					250	250	19	195	167	153	140	128	117	18.5				100	180					
																						250	232	199	181	167	152	139	22				100	180						
																							250	230	230	200	200	180	30				180							

Eg. Group1 pump with 3.15cc/rev gives flow rate of 4.6lpm, Max Pressure of 181bar, Motor 1.5kW, 30 Litre Tank

Design notes:-

In general the tank volume should be a minimum 3 times the flow rate. Eg – 30lpm flow = 100 Litre Tank